

# User Manual

Model Number: W60 / W61 / W62

## I. Product Overview

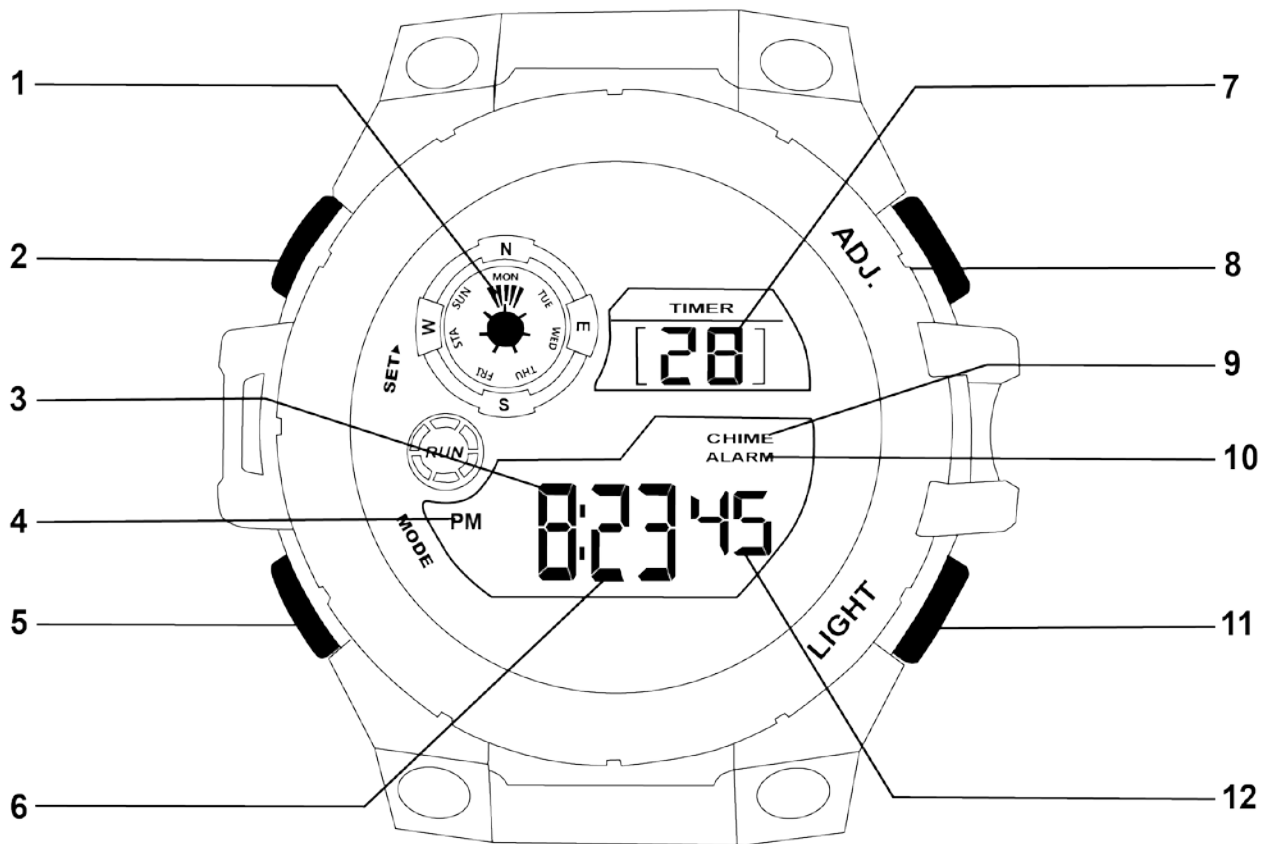

1. Week Day

2. Set Button

3. Hour

4. PM Indicator

5. Mode Button

6. Minute

7. Date

8. ADJ. Button

9. Hourly Chime Indicator

10. Alarm Indicator

11. Light Button

12. Second

## II. Local Time Setup

2.1 In the local time display mode, hold down the SET button till you see the second digit is blinking, then press the ADJ button to clear the second digit or you could skip to the next step.



2.2 Press the MODE button once, you will see the hour digit starts blinking, then press the ADJ button to set the hour.



2.3 Press the MODE button once again, you will see the minute digit starts blinking, then press the ADJ button to set the minute.



2.4 Press the MODE button once again, you will see the month digit starts blinking, then press the ADJ button to set the month.

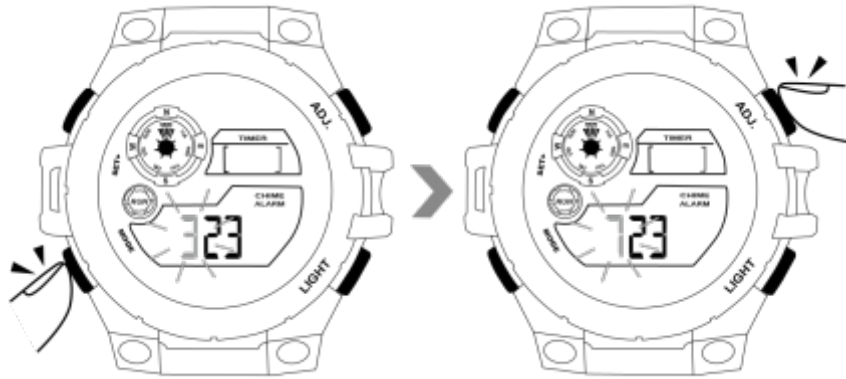

2.5 Press the MODE button once again, you will see the date digit starts blinking, then press the ADJ button to set the date.

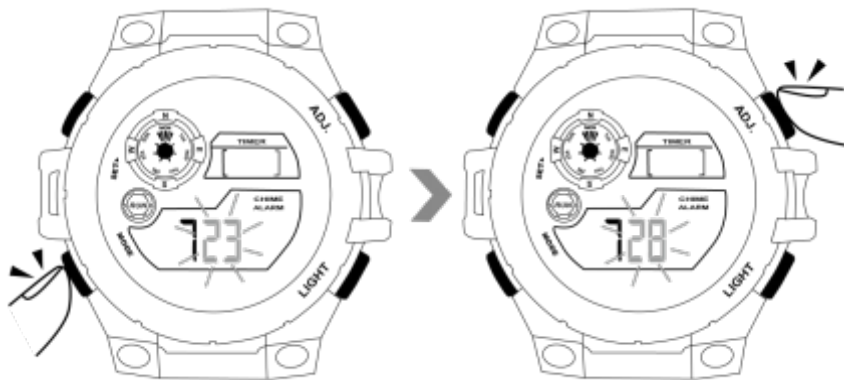

2.6 Press the MODE button once again, you will see the day indicator starts blinking, then press the ADJ button to set the day.

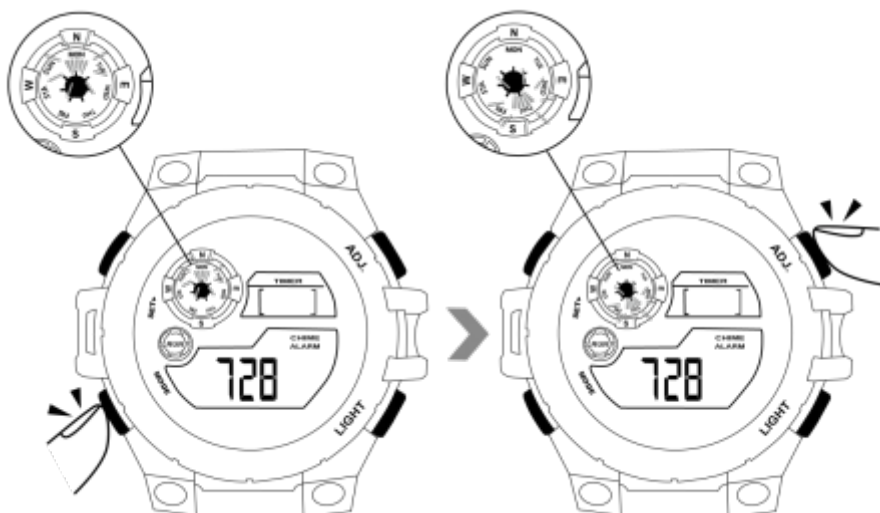

2.7 Press the MODE button once again, you will see the hour format digit indicator starts blinking, then press the ADJ button to choose 12 or 24 hours format.

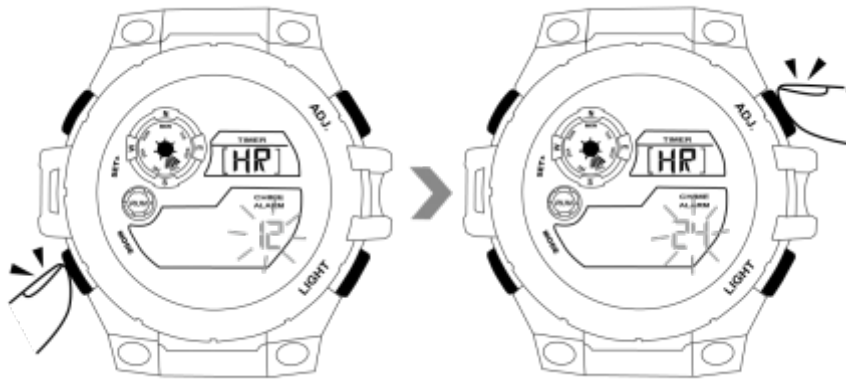

2.8 Press the SET button once to save all the settings, the watch will back to the local time display mode.

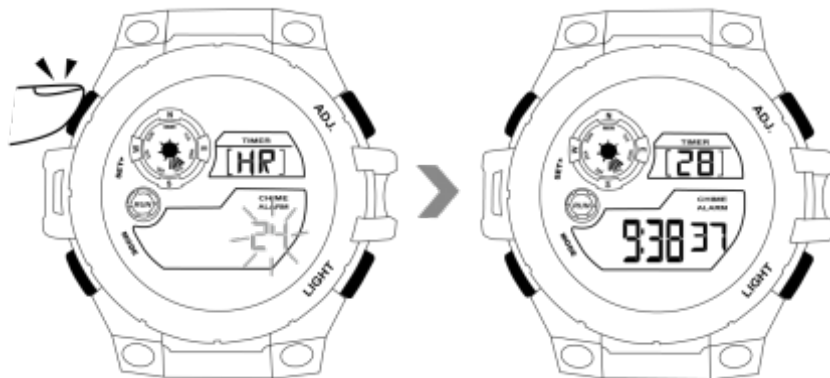

### III. Stopwatch Mode

3.1 In the local time display mode, press the MODE button once to enter into stopwatch mode.

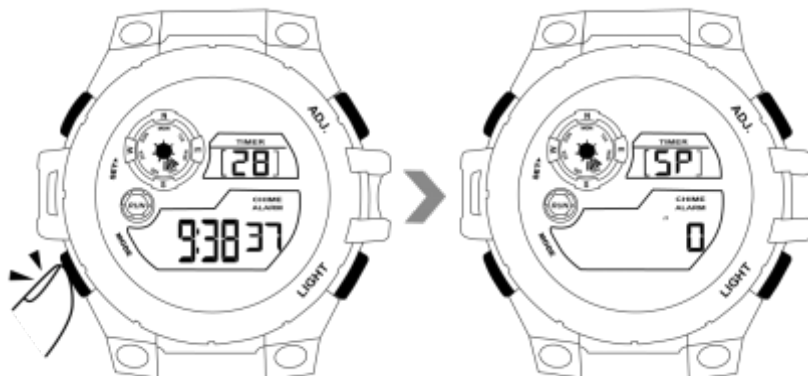

3.2 Press the ADJ button to start timing.



3.3 Press the ADJ button again to stop timing.



3.4 Press the SET button to clear.

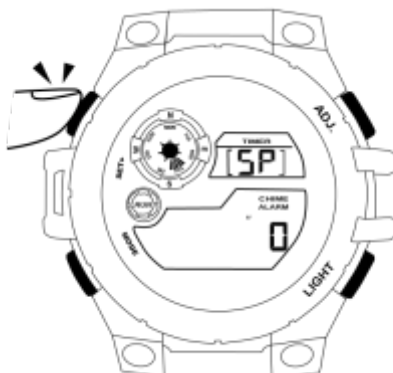

3.5 Press the MODE button once to exit the stopwatch mode.

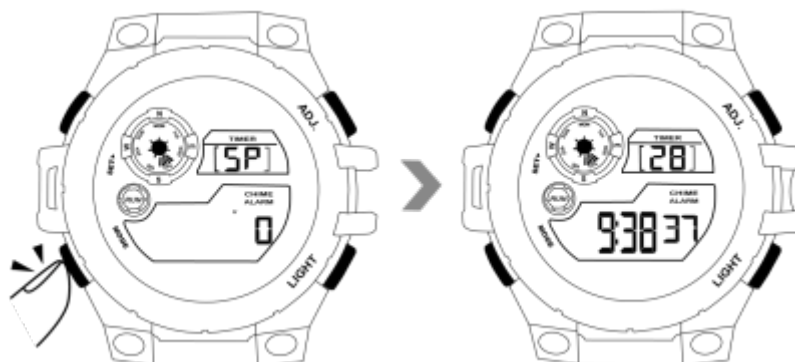

<Note>:

1. The stopwatch timing range is 0'00"00 to 23:59'59".
2. If you don't stop the timing, the stopwatch will continue to timing and start timing from 0'0"00 even the timing is over 24 hours and you have exited the stopwatch mode.

## IV. Alarm

### 4.1 Set an alarm

4.1.1 In the local time display mode, press the MODE button twice to enter into alarm setting mode.

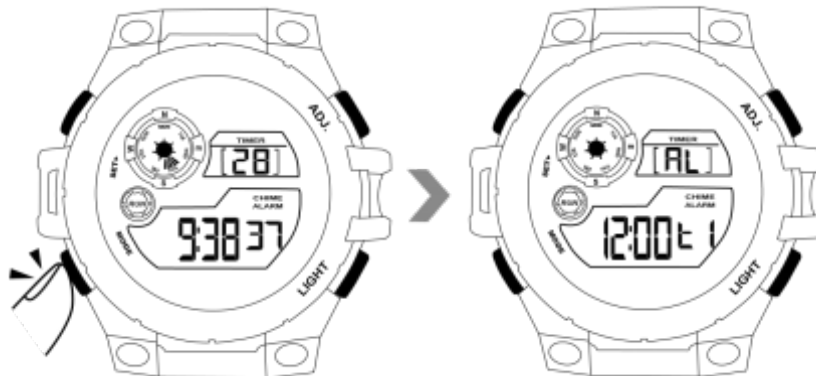

4.1.2 Hold down the SET button till you see the hour digit is blinking, then press the ADJ button to set the hour.

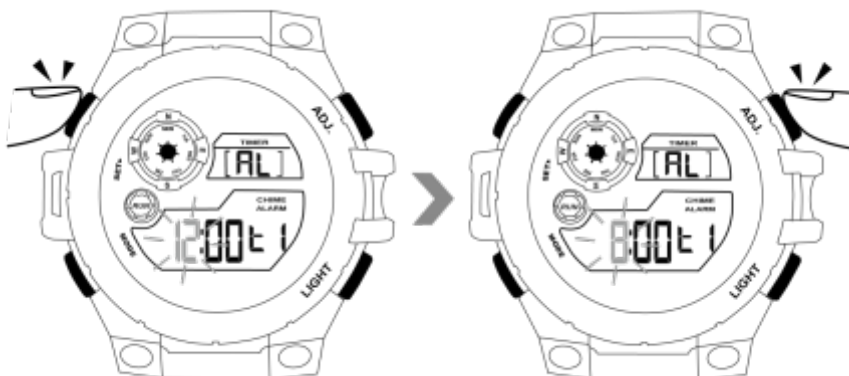

4.1.3 Press the MODE button once, you will see the minute digit starts blinking, then press the ADJ button to set the minute.

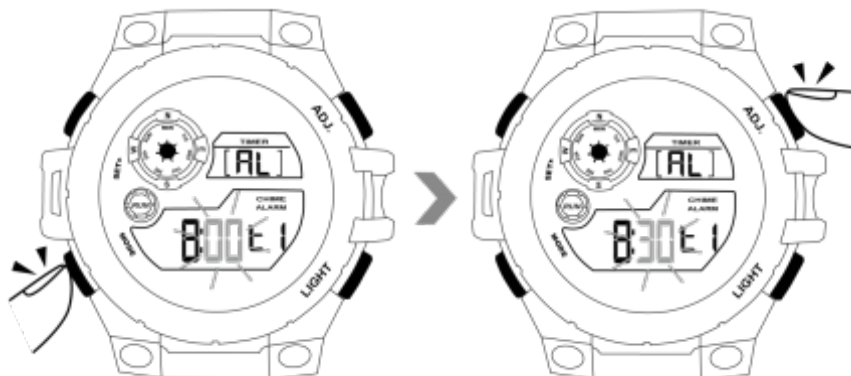

4.1.4 Press the MODE button once again, you will see the time zone digit indicator starts blinking, then press the ADJ button to select the time zone. **Note: L1 is the alarm for your local time zone, L2 is the alarm for the other time zone.**

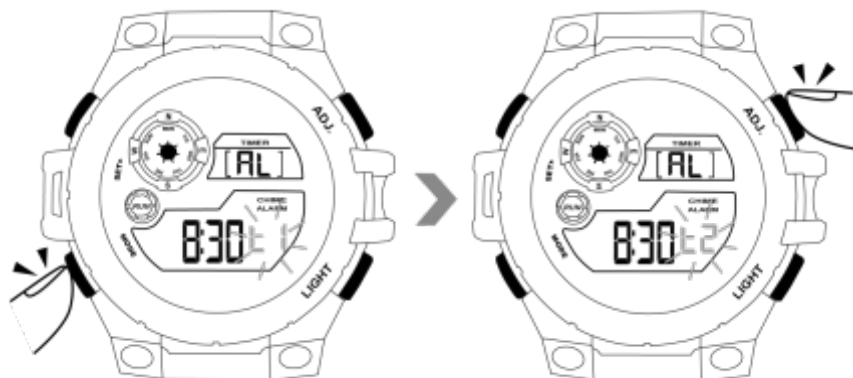

4.1.5 Press the SET button once to save the setting.

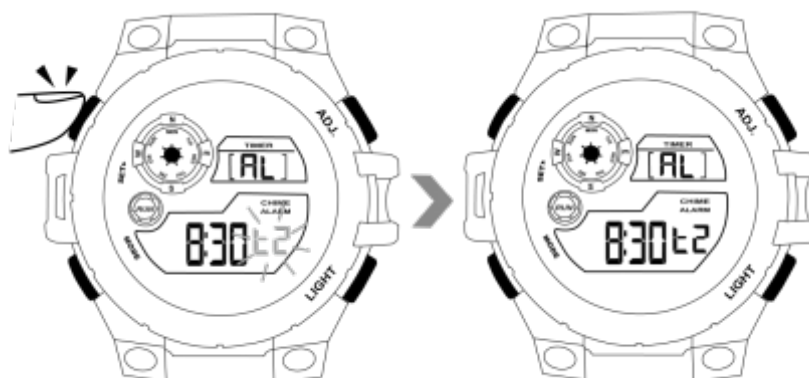

4.1.6 Press the MODE button once to exit the alarm setting mode.

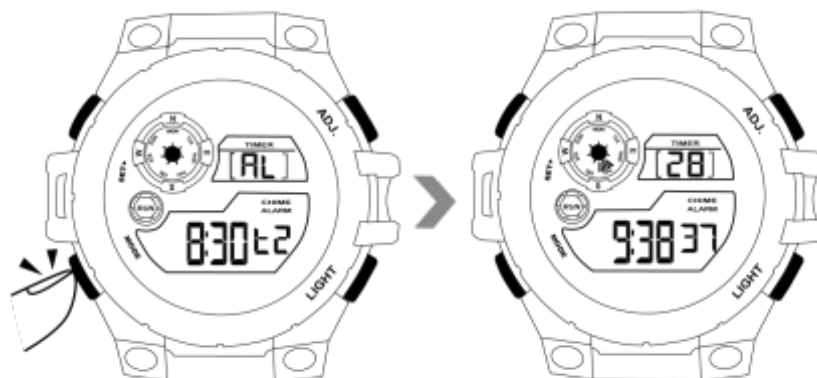

## 4.2 Turn On/Off Alarm

In the alarm setting mode, press the ADJ button to turn on or turn off the alarm.

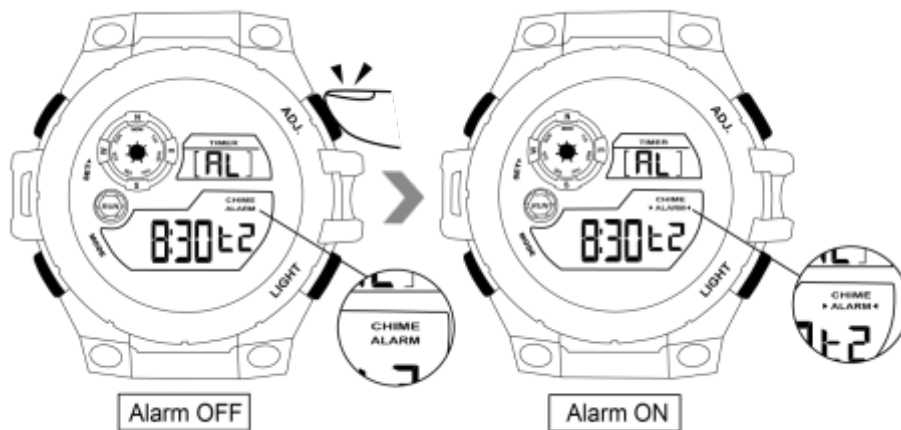

<Note>:

1. The alarm sound would last for 20 seconds.
2. You could press any buttons on the watch to stop the alarm sound.
3. The alarm is defaulted set for everyday.

## V. Turn On/Off Hourly Chime Function

5.1 In the alarm setting mode, press the ADJ button to turn on/off the hourly chime function.

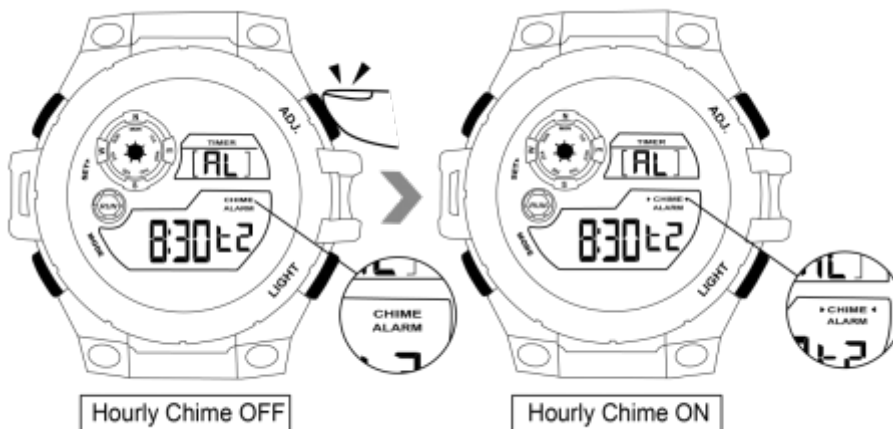



## VI. Timer Countdown

6.1 In the local time display mode, press the MODE button for 3 times to enter into timer countdown mode.

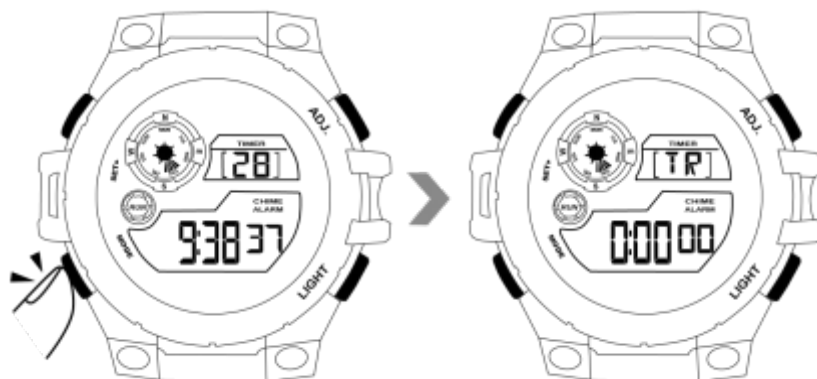

6.2 Hold down the SET button till you see the hour digit is blinking, then press the ADJ button to set the hour.

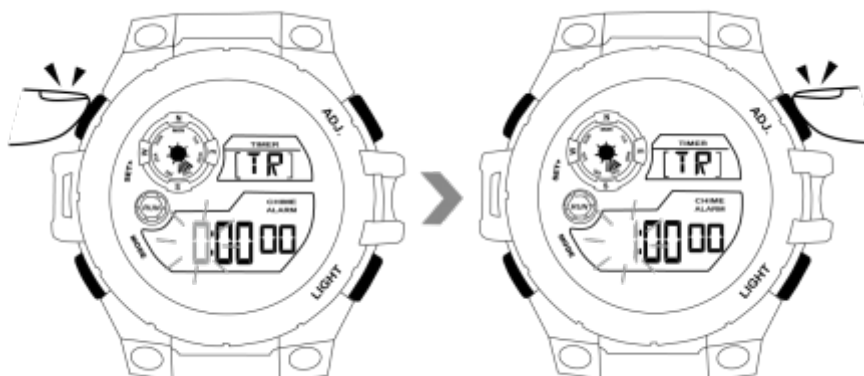

6.3 Press the MODE button once, you will see the minute digit starts blinking, then press the ADJ button to set the minute.

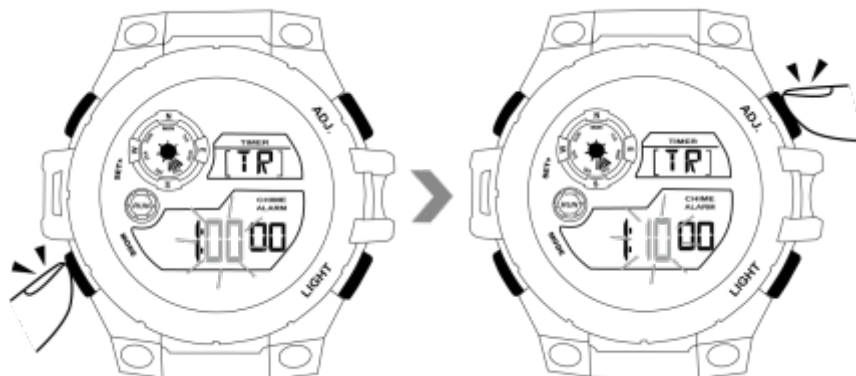

6.4 Press the MODE button once again, you will see the second digit starts blinking, then press the ADJ button to set the second.

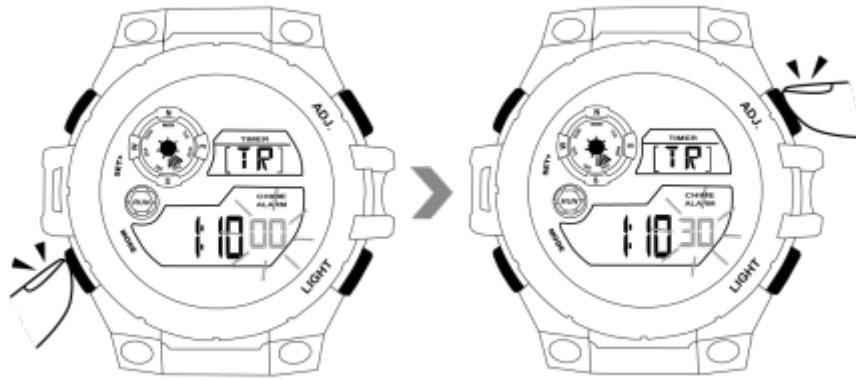

6.5 Press the SET button once to save the setting.

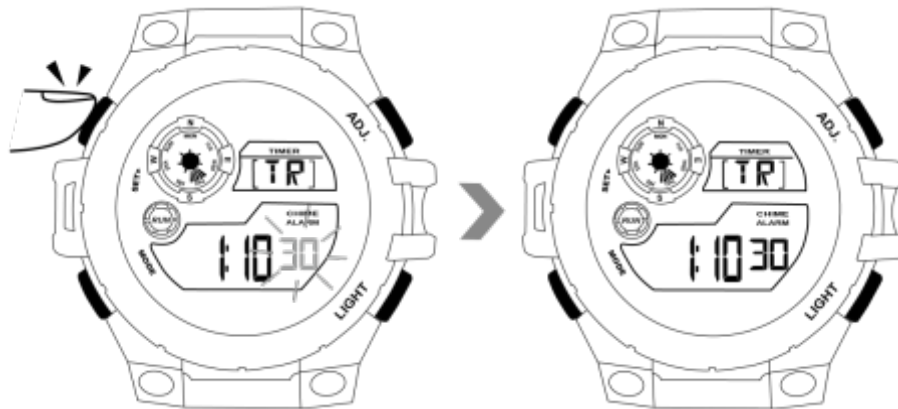

6.6 Press the ADJ button to start count down.



6.7 Press the ADJ button again to stop count down.



6.8 Press the MODE button once to exit the timer countdown.

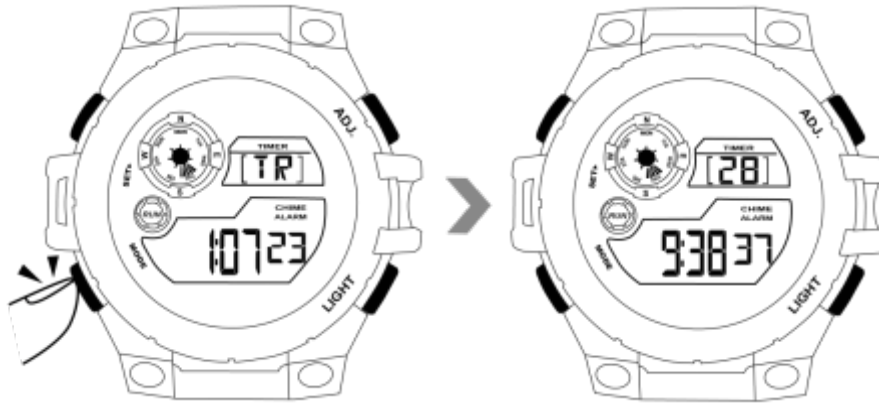

<Note>: When the countdown is ended, the watch will sound for 10 seconds and then return to the start.

## VII. Back Light

Press the LIGHT button to turn on the electro luminescent backlight. The backlight will be turned off automatically in about 3 seconds.



## VIII. Time Setup for the Other Time Zone

8.1 In the local time display mode, press the MODE button for 4 times to enter into the other time zone display mode.

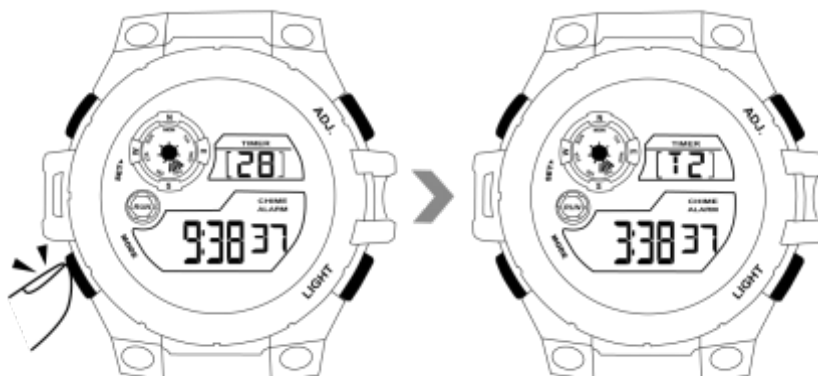

8.2 Hold down the SET button till you see the hour digit is blinking, then press the ADJ button to set the hour.

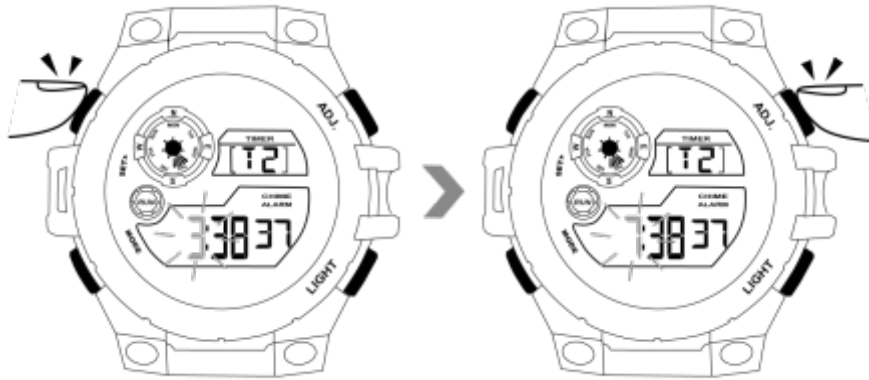

8.3 Press the MODE button once, you will see the minute digit starts blinking, then press the ADJ button to set the minute.

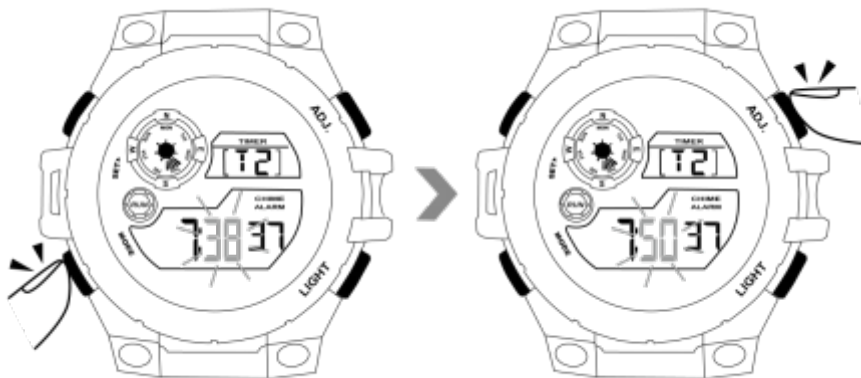

8.4 Press the SET button to save the setting.

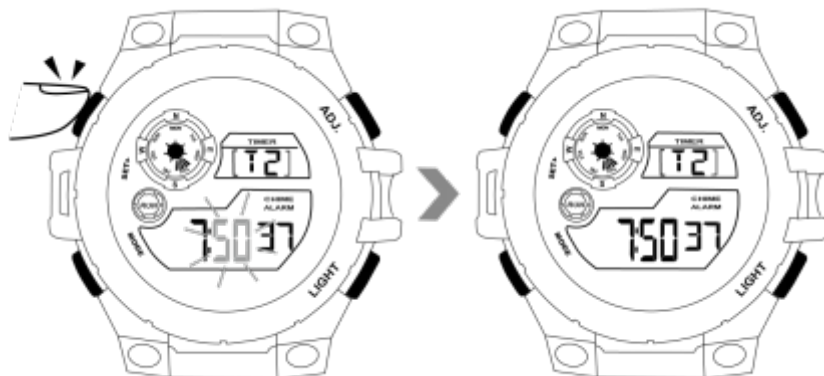

8.5 Press the MODE button once to exit the display mode of other time zone.

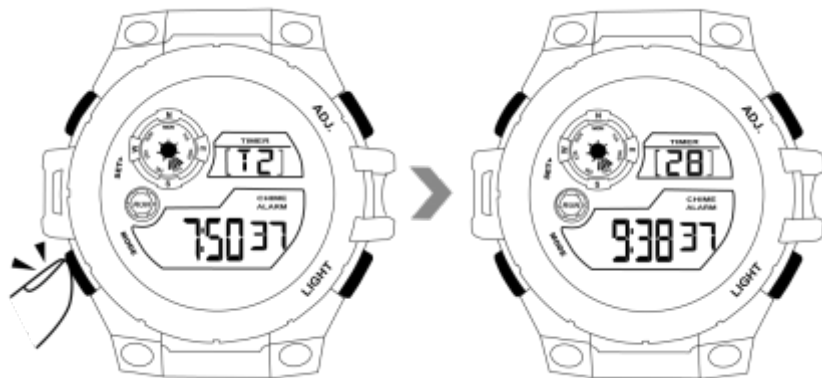

## IX. Month and Date Check

In the local time display mode, hold down the ADJ button to check the month and date.



## X. Check the Current Time in the Other Time Zone

In the local time display mode, press the MODE button for 4 times to check the current time in the other time zone



<The End>

# Benutzerhandbuch

Modell-Nr: W60 / W61 / W62

## I. Produktübersicht

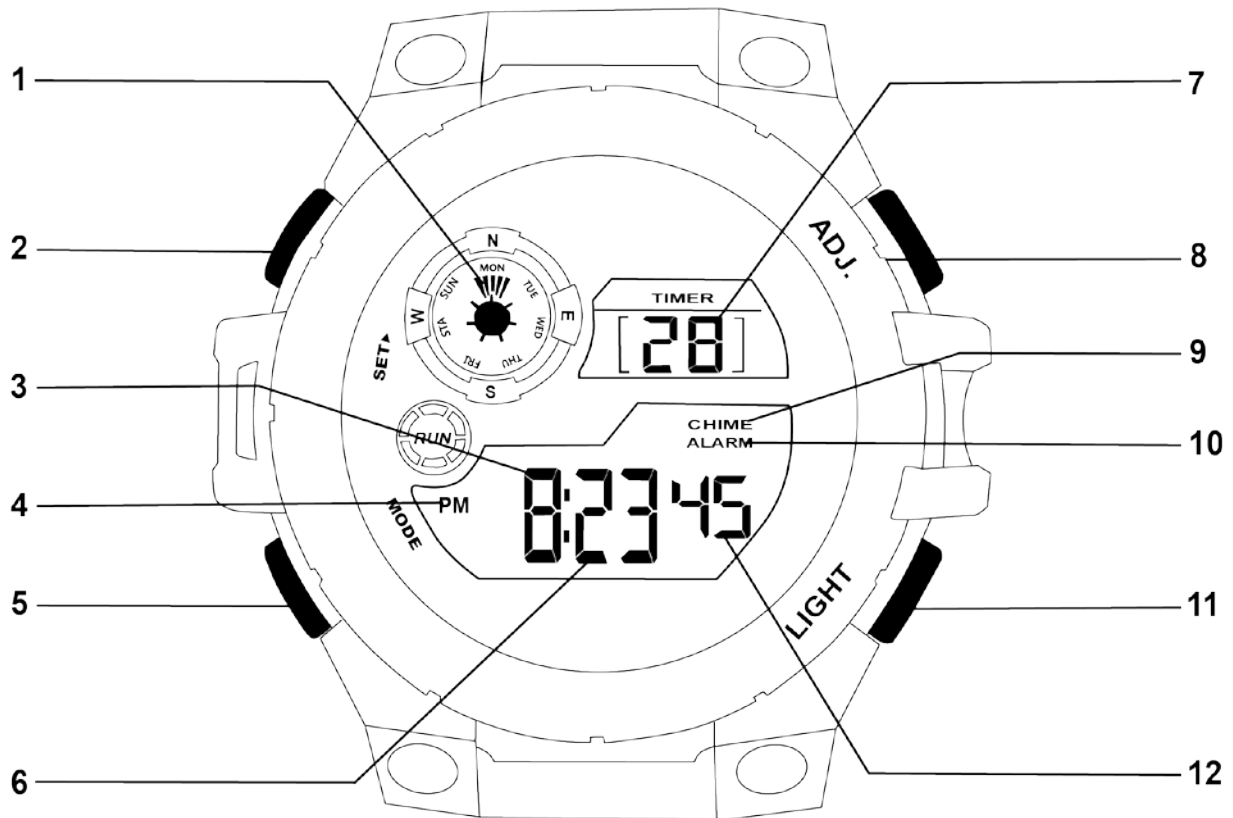

1. Tag

2. Set-Taste

3. Stunde

4. PM-Anzeige

5. Modustaste

6. Minute

7. Datum

8. ADJ Button

9. Stundensignalanzeige

10. Alarmanzei

11. Lichtknopf

12. Sekunden

## II. Lokale Zeiteinstellung

2.1 Halten Sie im Ortszeit-Anzeigemodus die SET-Taste gedrückt, bis die Sekundenanzeige blinkt, und drücken Sie dann die ADJ-Taste, um die Sekundenanzeige zu löschen.

Andernfalls können Sie zum nächsten Schritt übergehen.



2.2 Drücken Sie die MODE-Taste einmal. Die Stundenanzeige beginnt zu blinken. Drücken Sie dann die ADJ-Taste, um die Stunde einzustellen.

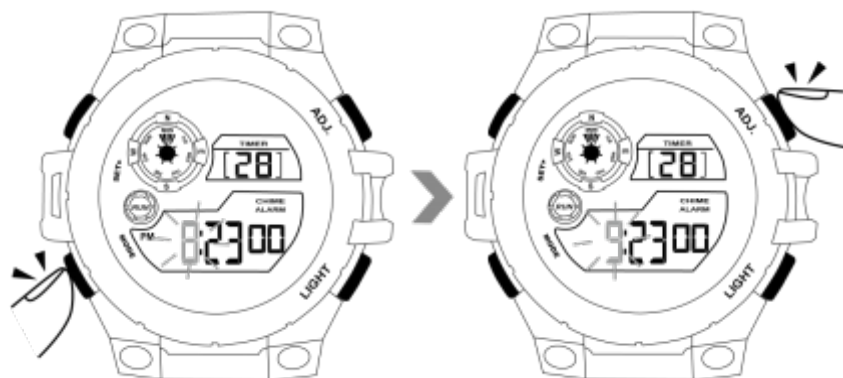

2.3 Drücken Sie die MODE-Taste erneut. Die Minutenanzeige beginnt zu blinken. Drücken Sie dann die ADJ-Taste, um die Minuten einzustellen.



2.4 Drücken Sie die MODE-Taste erneut. Die Monatsziffer beginnt zu blinken. Drücken Sie dann die ADJ-Taste, um den Monat einzustellen.



2.5 Drücken Sie die MODE-Taste erneut. Die Datumsanzeige beginnt zu blinken. Drücken Sie anschließend die ADJ-Taste, um das Datum einzustellen.

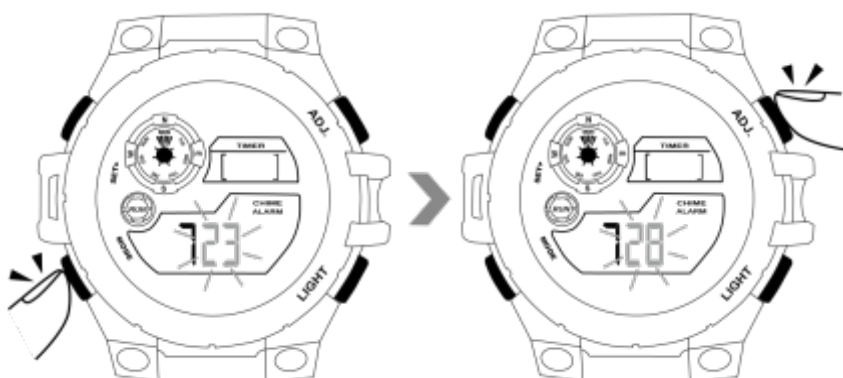

2.6 Drücken Sie die MODE-Taste erneut. Die Tagesanzeige beginnt zu blinken. Drücken Sie anschließend die ADJ-Taste, um den Tag einzustellen.

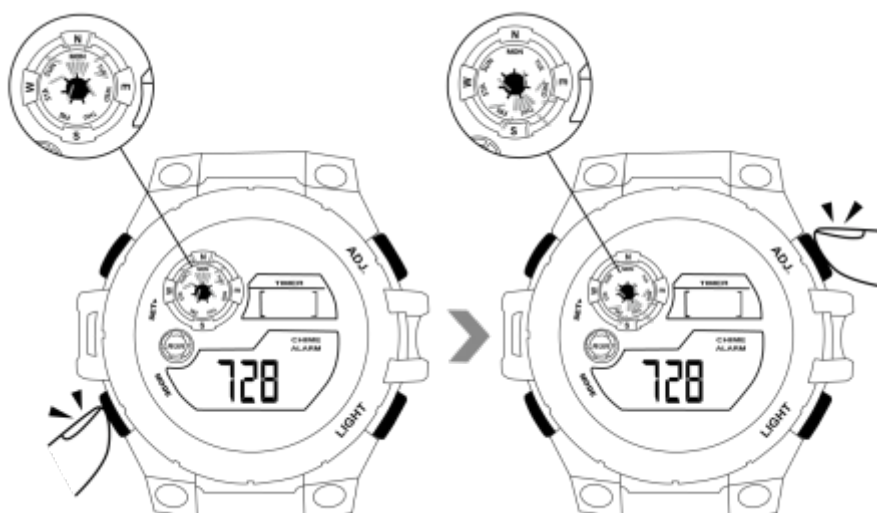



2.7 Drücken Sie die MODE-Taste erneut. Die Stundenformat-Ziffernanzeige beginnt zu blinken. Drücken Sie dann die ADJ-Taste, um das 12- oder 24-Stunden-Format auszuwählen.

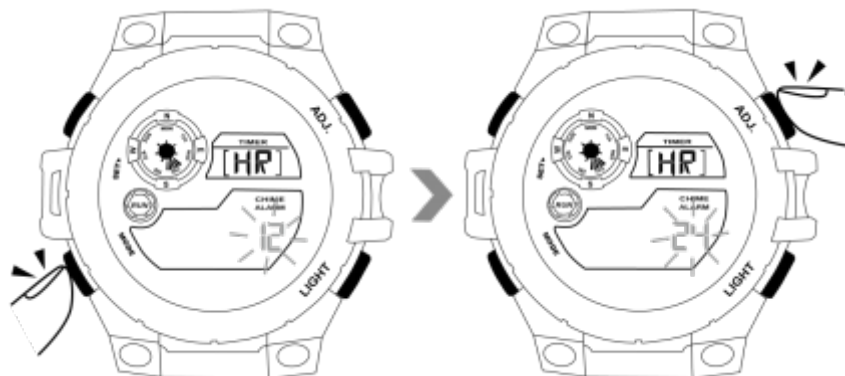

2.8 Drücken Sie die SET-Taste einmal, um alle Einstellungen zu speichern. Die Uhr kehrt in den Ortszeit-Anzeigemodus zurück.

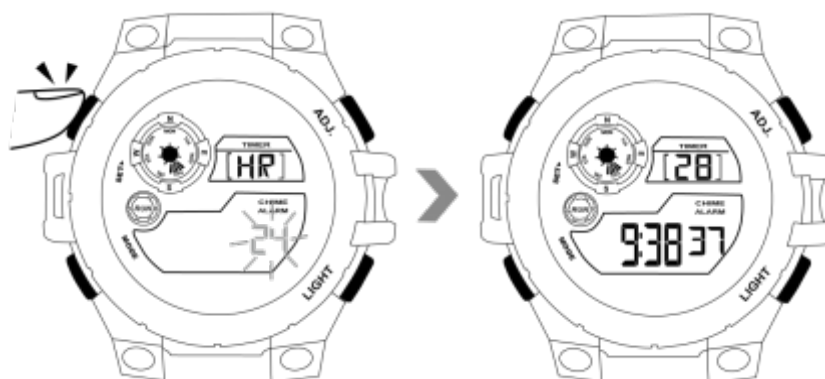

### III. Stoppuhr-Modus

3.1 Drücken Sie im Ortszeit-Anzeigemodus einmal die MODE-Taste, um in den Stoppuhr-Modus zu gelangen.

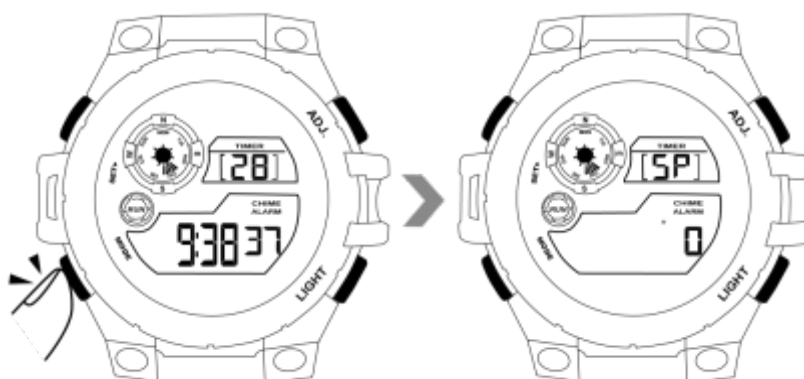

3.2 Drücken Sie die ADJ-Taste, um das Timing zu starten.



3.3 Drücken Sie die ADJ-Taste erneut, um das Timing anzuhalten.



3.4 Drücken Sie die SET-Taste zum Löschen.

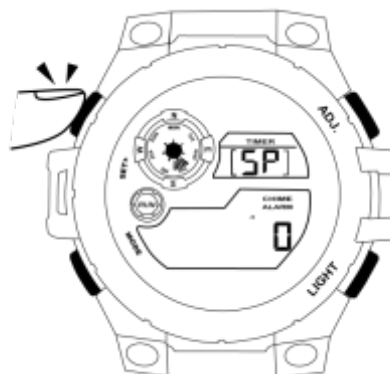

3.5 Drücken Sie die MODE-Taste einmal, um den Stoppuhrmodus zu verlassen.

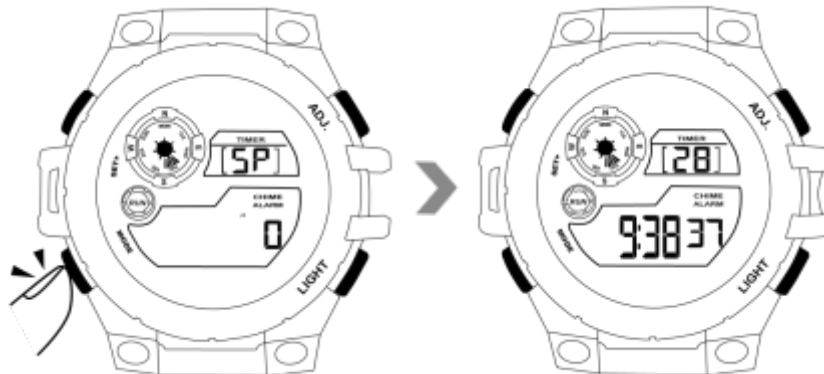

<Hinweis> :

1. Der Stoppuhr-Zeitbereich beträgt 0'00 "00 bis 23: 59'59".
2. Wenn Sie das Timing nicht anhalten, fährt die Stoppuhr mit dem Timing fort und startet das Timing von 0'0"00, auch wenn das Timing über 24 Stunden liegt und Sie den Stoppuhrmodus verlassen haben.

## IV. Wecker

### 4.1 Wecker einstellen

4.1.1 Drücken Sie im Ortszeit-Anzeigemodus die MODE-Taste zweimal, um in den Weckereinstellungsmodus zu gelangen.

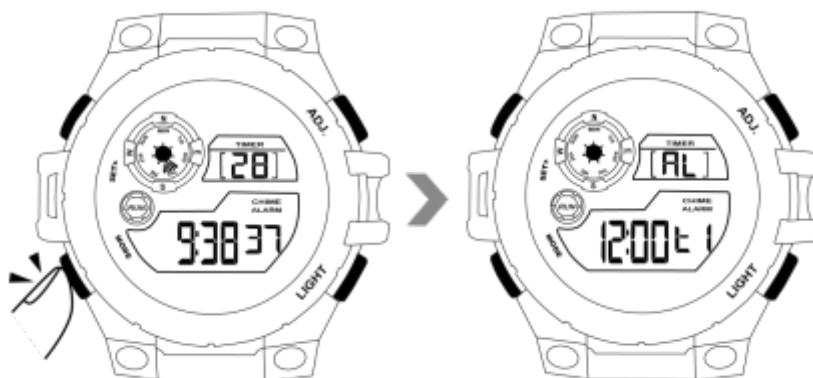

4.1.2 Halten Sie die SET-Taste gedrückt, bis die Stundenanzeige blinkt, und drücken Sie dann die ADJ-Taste, um die Stunde einzustellen.



4.1.3 Drücken Sie die MODE-Taste einmal. Die Minutenanzeige beginnt zu blinken. Drücken Sie dann die ADJ-Taste, um die Minuten einzustellen.



4.1.4 Drücken Sie die MODE-Taste erneut. Die Zeitzoneanzeige beginnt zu blinken. Drücken Sie dann die ADJ-Taste, um die Zeitzone auszuwählen. **Hinweis: L1 ist der Wecker für Ihre lokale Zeitzone, L2 ist der Wecker für die andere Zeitzone.**

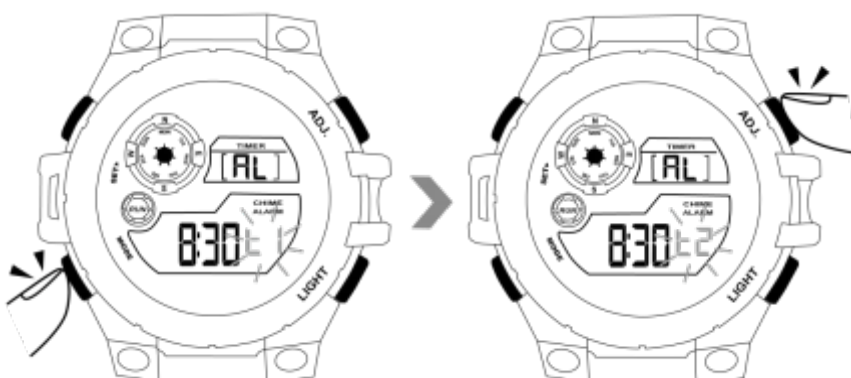

4.1.5 Drücken Sie die SET-Taste einmal, um die Einstellung zu speichern.

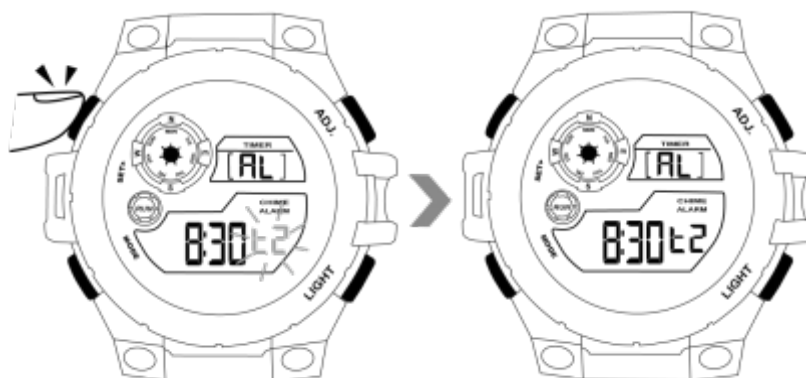

4.1.6 Drücken Sie die MODE-Taste einmal, um den Weckereinstellungsmodus zu verlassen.

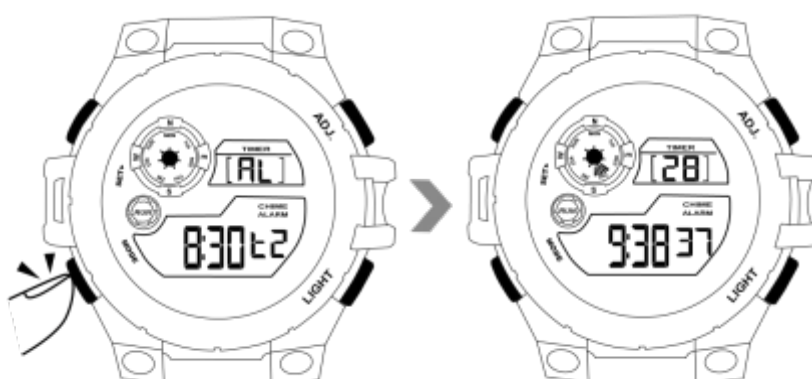

## 4.2 Ein- / Ausschalten des Alarms

Drücken Sie im Weckereinstellungsmodus die ADJ-Taste, um den Wecker ein- oder auszuschalten.

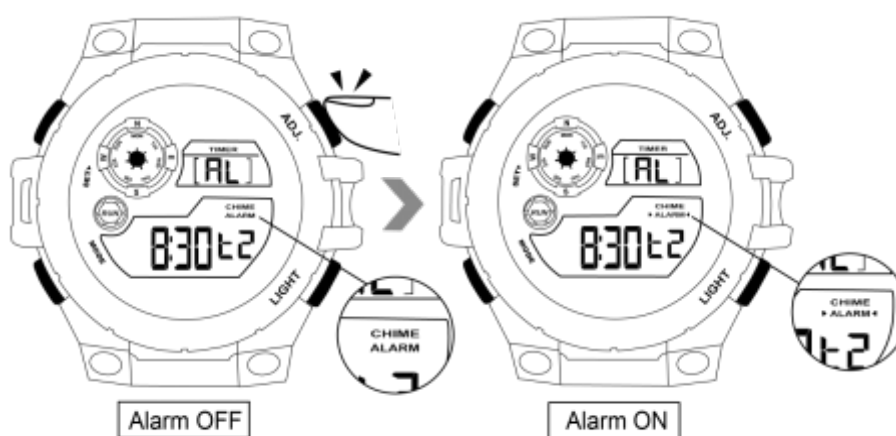

<Hinweis>:

1. Der Alarmton würde 20 Sekunden lang anhalten.
2. Sie können beliebige Tasten auf der Uhr drücken, um den Alarmton zu stoppen.
3. Der Alarm ist standardmäßig für den täglichen Gebrauch eingestellt.

## V. Ein- / Ausschalten der Stundensignalfunktion

5.1 Drücken Sie im Weckereinstellungsmodus die ADJ-Taste, um die Stundensignalfunktion ein- oder auszuschalten.

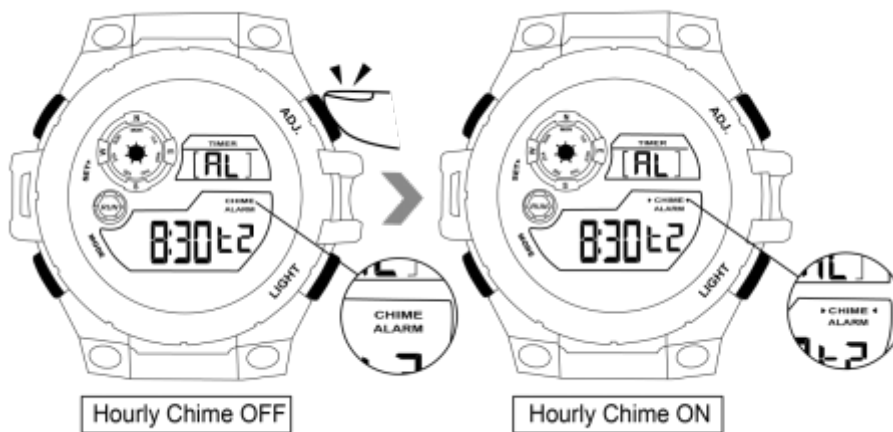

## VI. Timer Countdown

6.1 Drücken Sie im lokalen Zeitanzeigemodus die MODE-Taste dreimal, um in den Timer-Countdown-Modus zu gelangen.

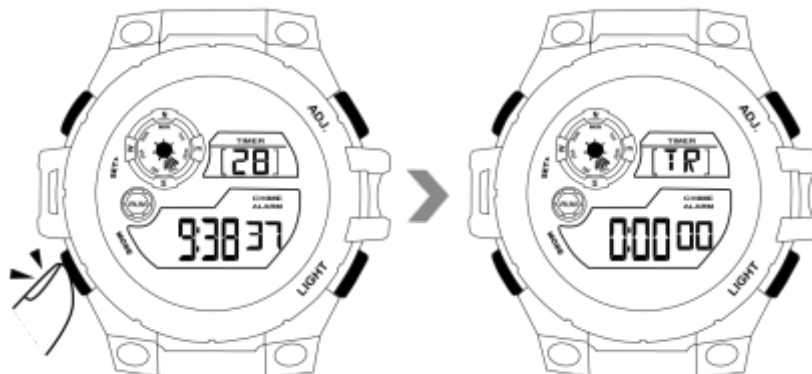

6.2 Halten Sie die SET-Taste gedrückt, bis die Stundenanzeige blinkt, und drücken Sie dann die ADJ-Taste, um die Stunde einzustellen.

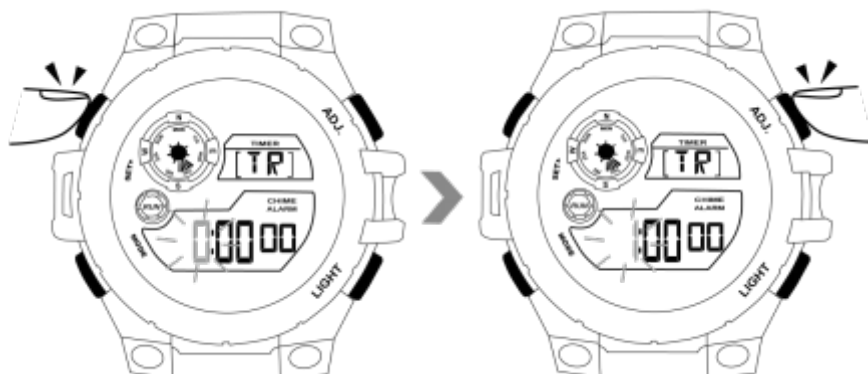

6.3 Drücken Sie die MODE-Taste einmal. Die Minutenanzeige beginnt zu blinken. Drücken Sie dann die ADJ-Taste, um die Minuten einzustellen.

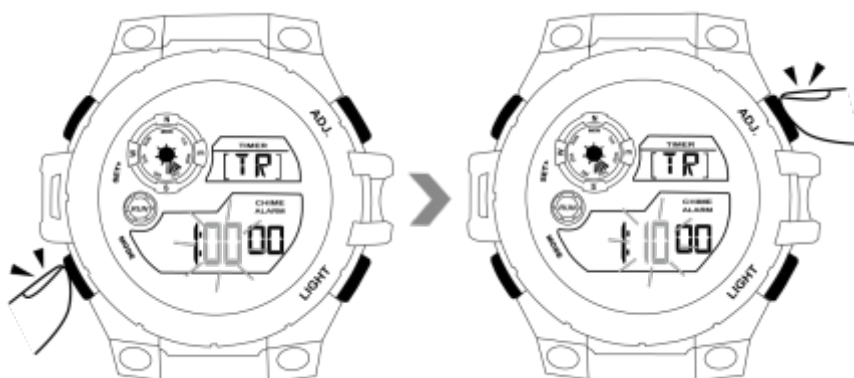

6.4 Drücken Sie die MODE-Taste erneut. Die Sekundenanzeige beginnt zu blinken. Drücken Sie anschließend die ADJ-Taste, um die Sekunden einzustellen.

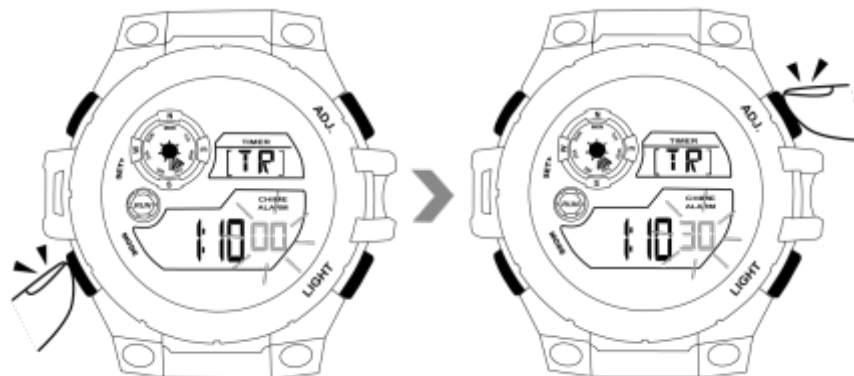

6.5 Drücken Sie die SET-Taste einmal, um die Einstellung zu speichern.

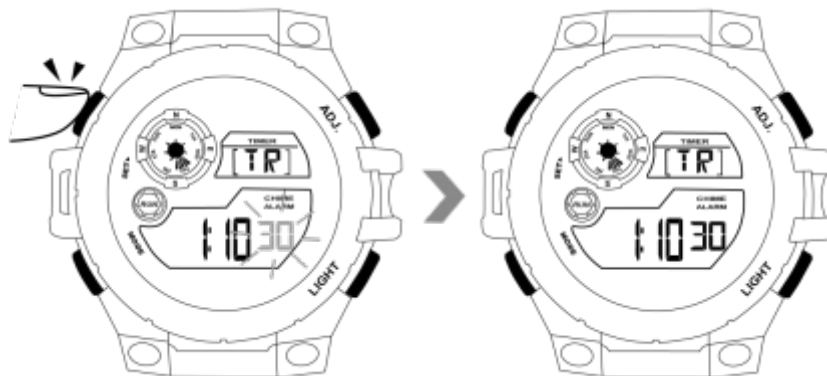

6.6 Drücken Sie die ADJ-Taste, um den Countdown zu starten.



6.7 Drücken Sie die ADJ-Taste erneut, um den Countdown abzubrechen.





6.8 Drücken Sie die MODE-Taste einmal, um den Timer-Countdown zu beenden.

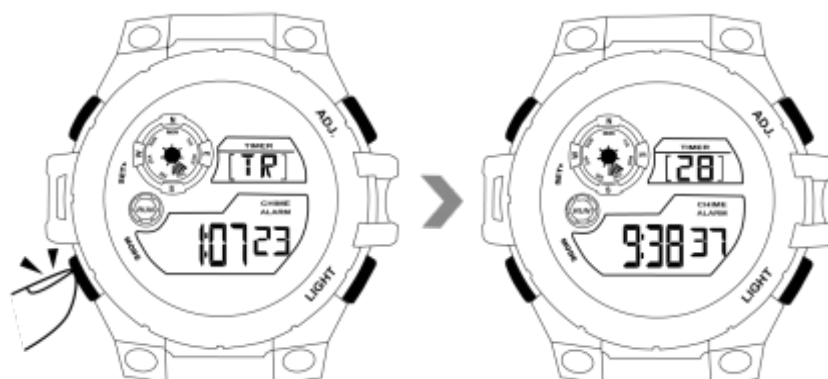

*<Hinweis>: Wenn der Countdown beendet ist, ertönt die Uhr 10 Sekunden lang und kehrt dann zum Start zurück.*

## VII. Gegenlicht

Drücken Sie die LIGHT-Taste, um die elektrolumineszierende Hintergrundbeleuchtung einzuschalten. Die Hintergrundbeleuchtung wird nach ca. 3 Sekunden automatisch ausgeschaltet.



## VIII. Zeiteinstellung für die andere Zeitzone

8.1 Drücken Sie im lokalen Zeitanzeigemodus die MODE-Taste viermal, um in den anderen Zeitzeitanzeigemodus zu gelangen.

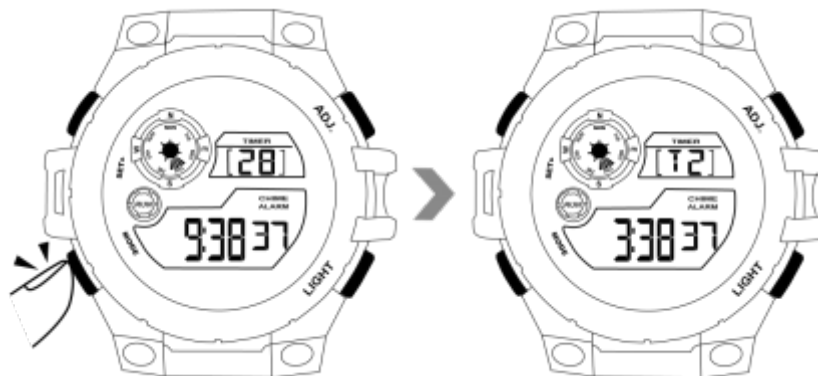

8.2 Halten Sie die SET-Taste gedrückt, bis die Stundenanzeige blinkt, und drücken Sie dann die ADJ-Taste, um die Stunde einzustellen.

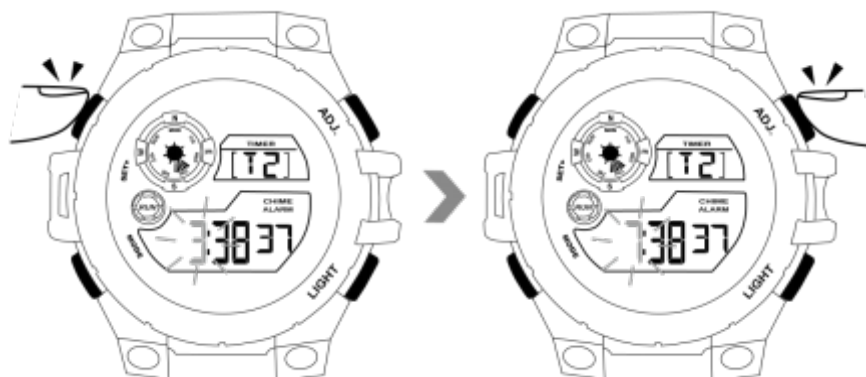

8.3 Drücken Sie die MODE-Taste einmal. Die Minutenanzeige beginnt zu blinken. Drücken Sie dann die ADJ-Taste, um die Minuten einzustellen.

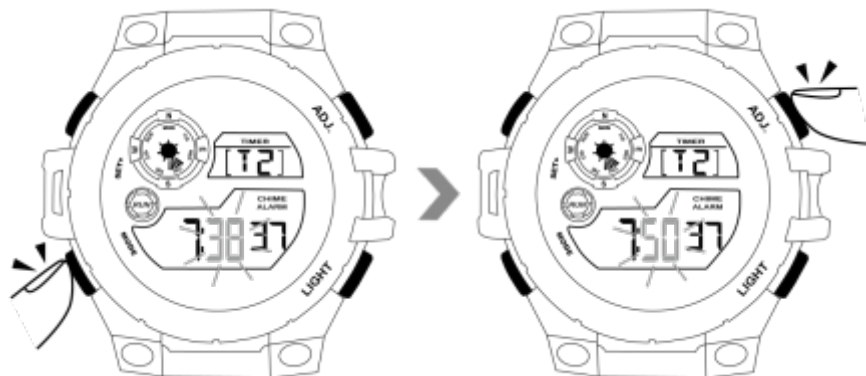

8.4 Drücken Sie die SET-Taste, um die Einstellung zu speichern.

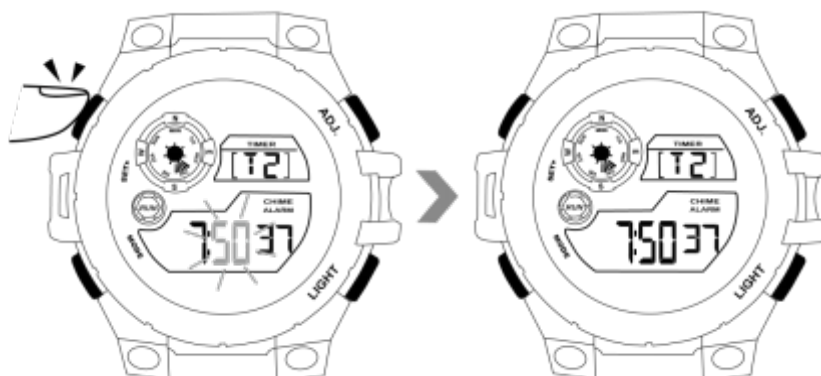

8.5 Drücken Sie die MODE-Taste einmal, um den anderen Zeitzone-Anzeigemodus zu verlassen.

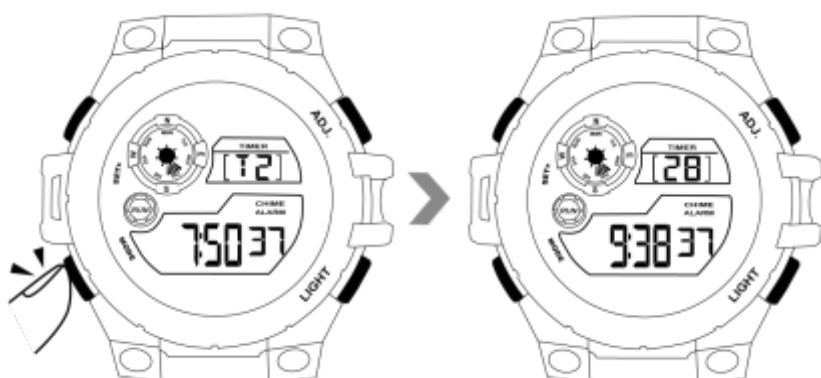

## IX. Monats- und Datumsüberprüfung

Halten Sie im lokalen Zeitanzeigemodus die ADJ-Taste gedrückt, um den Monat und das Datum zu überprüfen.



## X. Überprüfen Sie die aktuelle Zeit in der anderen Zeitzone

Drücken Sie im lokalen Zeitanzeigemodus die MODE-Taste viermal, um die aktuelle Zeit in der anderen Zeitzone zu überprüfen.



<Das Ende>

# Mode d'emploi

Numéro de modèle: W60 / W61 / W62

## I. Présentation du produit

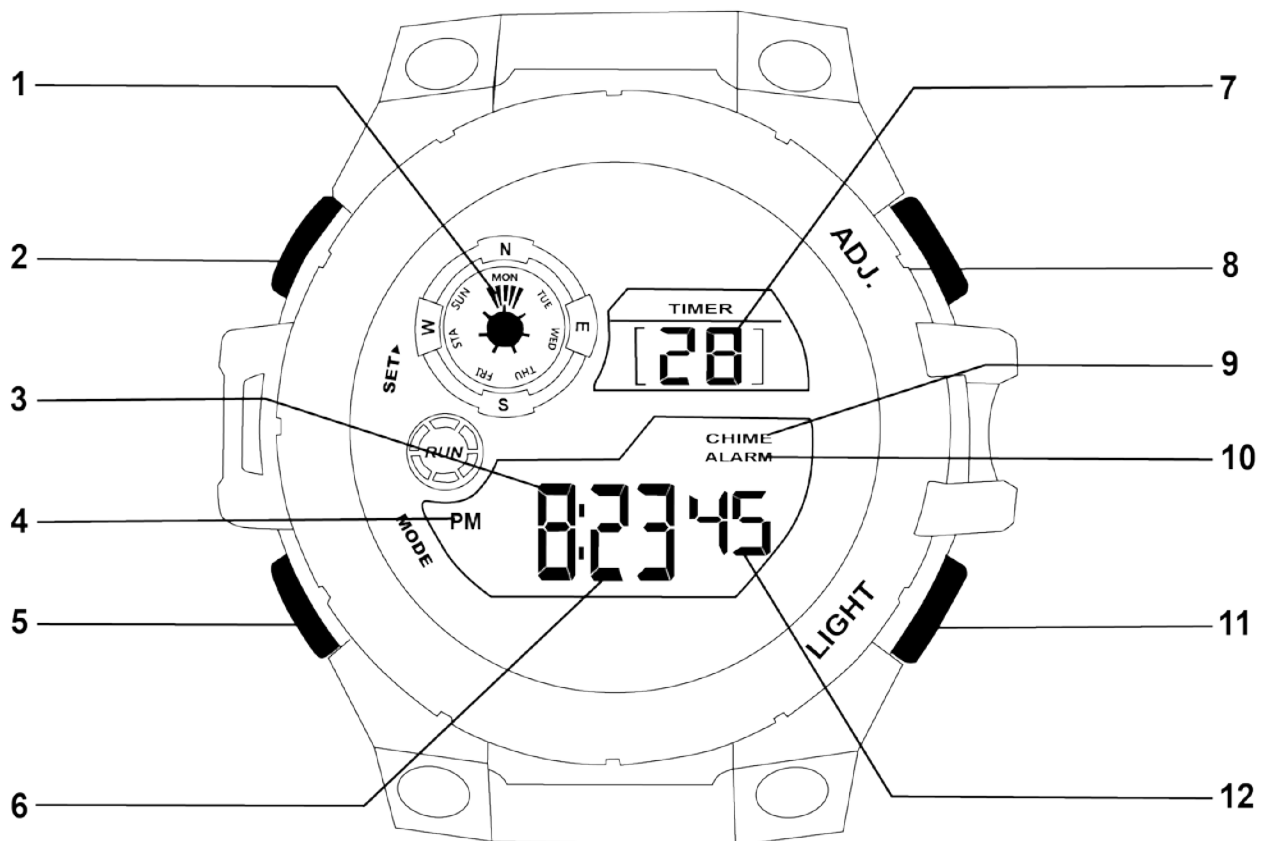

1. Journée

2. Bouton de réglage

3. Heure

4. Indicateur de PM

5. Bouton de mode

6. Minute

7. Date

8. Bouton ADJ

9. Indicateur horaire de carillon

10. Indicateur d'alarme

11. Bouton lumière

12. Second

## II. Réglage de l'heure locale

2.1 En mode d'affichage de l'heure locale, maintenez la touche SET enfoncée jusqu'à ce que le chiffre des secondes clignote, puis appuyez sur la touche ADJ pour effacer le chiffre des secondes ou passez directement à l'étape suivante.



2.2 Appuyez une fois sur le bouton MODE, vous verrez que le chiffre des heures commence à clignoter, puis appuyez sur le bouton ADJ pour régler les heures.



2.3 Appuyez à nouveau sur le bouton MODE, vous verrez le chiffre des minutes commencer à clignoter, puis appuyez sur le bouton ADJ pour régler les minutes.



2.4 Appuyez à nouveau sur le bouton MODE, vous verrez que le chiffre du mois commence à clignoter, puis appuyez sur le bouton ADJ pour régler le mois.

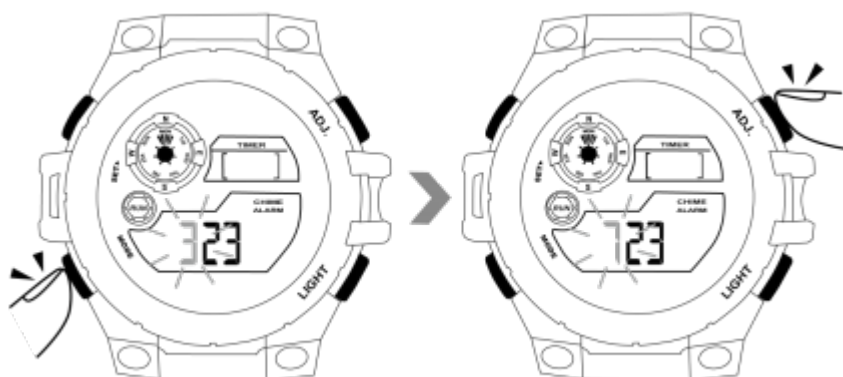

2.5 Appuyez à nouveau sur le bouton MODE, le chiffre de la date commence à clignoter, puis appuyez sur le bouton ADJ pour régler la date.

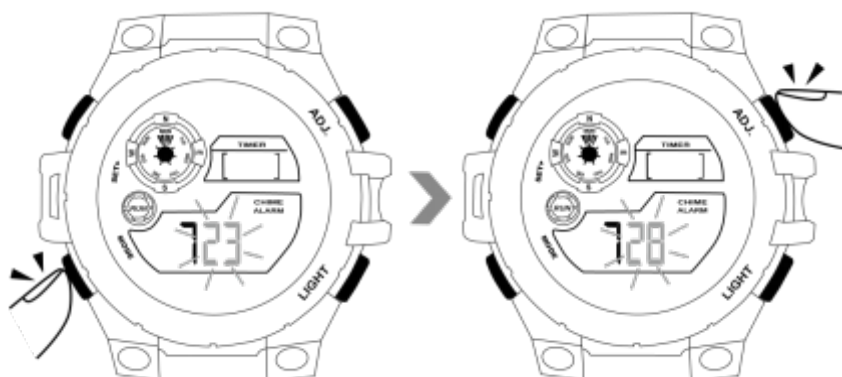

2.6 Appuyez à nouveau sur le bouton MODE, vous verrez l'indicateur du jour se mettre à clignoter, puis appuyez sur le bouton ADJ pour régler le jour.

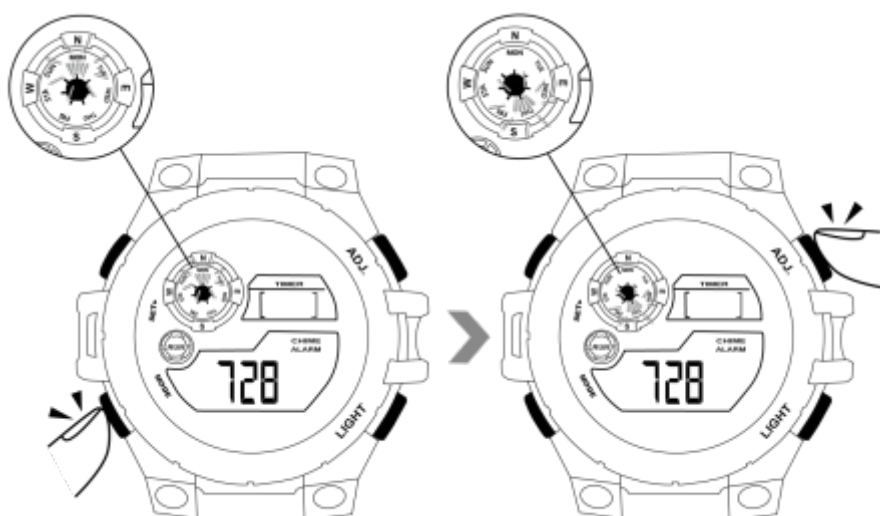

2.7 Appuyez à nouveau sur le bouton MODE, vous verrez l'indicateur de format de l'heure se mettre à clignoter, puis appuyez sur le bouton ADJ pour choisir le format 12 ou 24 heures.

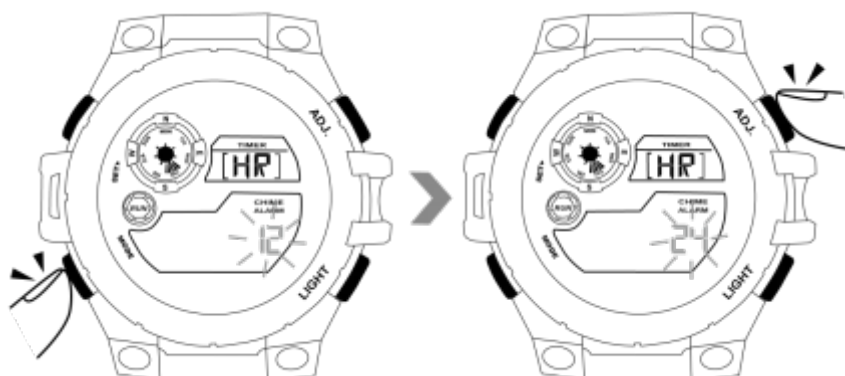

2.8 Appuyez une fois sur le bouton SET pour enregistrer tous les réglages. La montre reviendra au mode d'affichage de l'heure locale.

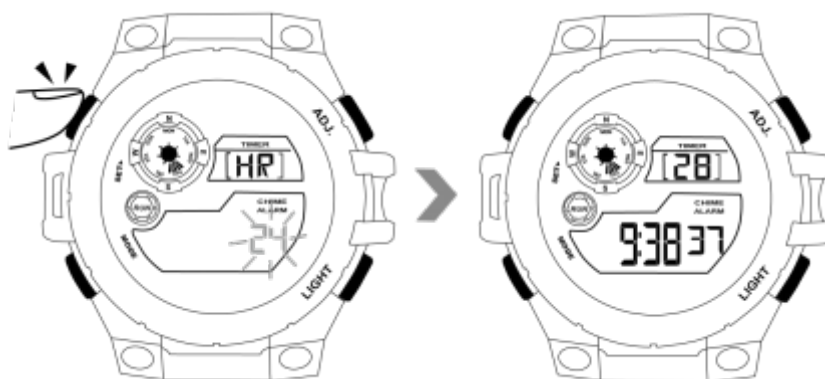

### III. Mode chronomètre

3.1 En mode d'affichage de l'heure locale, appuyez une fois sur le bouton MODE pour entrer en mode chronomètre.

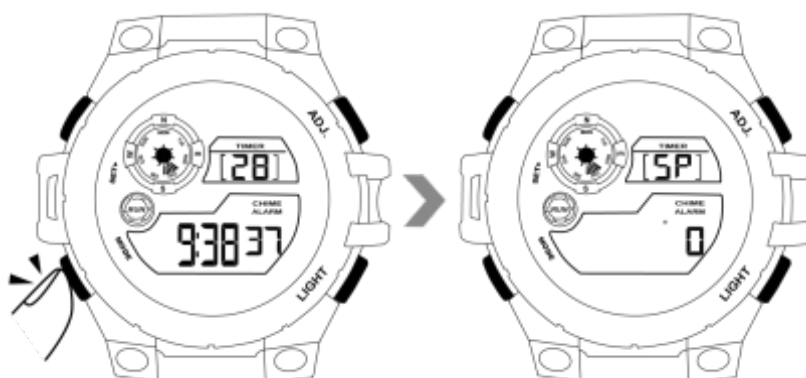



3.2 Appuyez sur le bouton ADJ pour commencer le chronométrage.



3.3 Appuyez à nouveau sur le bouton ADJ pour arrêter le chronométrage.



3.4 Appuyez sur le bouton SET pour effacer.

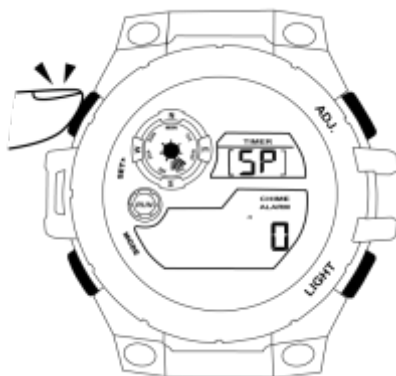

3.5 Appuyez une fois sur le bouton MODE pour quitter le mode chronomètre.

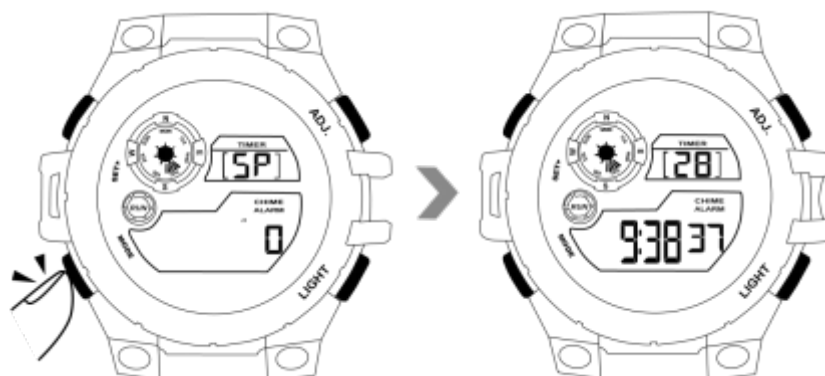

< Remarque >:

1. La plage de chronométrage du chronomètre est comprise entre 0'00 "00 et 23: 59'59".
2. Si vous n'arrêtez pas le chronométrage, le chronomètre continuera à chronométrer et commencera à chronométrer à partir de 0'0"00, même si le chronométrage est supérieur à 24 heures et vous avez quitté le mode chronomètre.

## IV. Alarme

### 4.1 Mettre une alarme

4.1.1 En mode d'affichage de l'heure locale, appuyez deux fois sur le bouton MODE pour passer en mode de réglage de l'alarme.

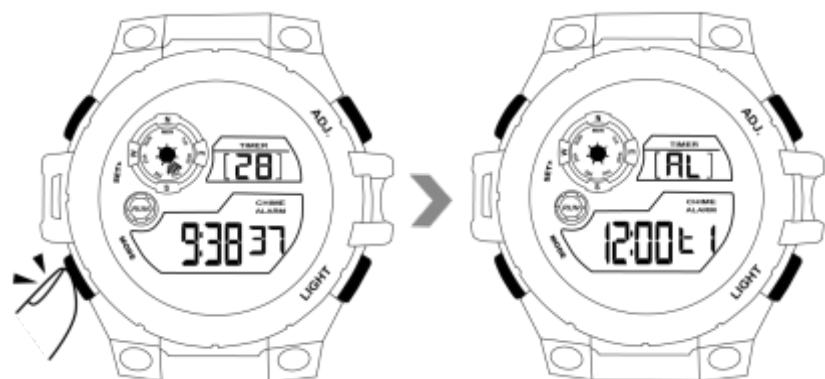

4.1.2 Maintenez le bouton SET enfoncé jusqu'à ce que le chiffre des heures clignote, puis appuyez sur le bouton ADJ pour régler l'heure.



4.1.3 Appuyez une fois sur le bouton MODE, le chiffre des minutes commence à clignoter, puis appuyez sur le bouton ADJ pour régler les minutes.



4.1.4 Appuyez à nouveau sur le bouton MODE, vous verrez l'indicateur de chiffre du fuseau horaire commencer à clignoter, puis appuyez sur le bouton ADJ pour sélectionner le fuseau horaire. **Remarque: L1 est l'alarme de votre fuseau horaire local, L2 l'alarme de l'autre fuseau horaire.**

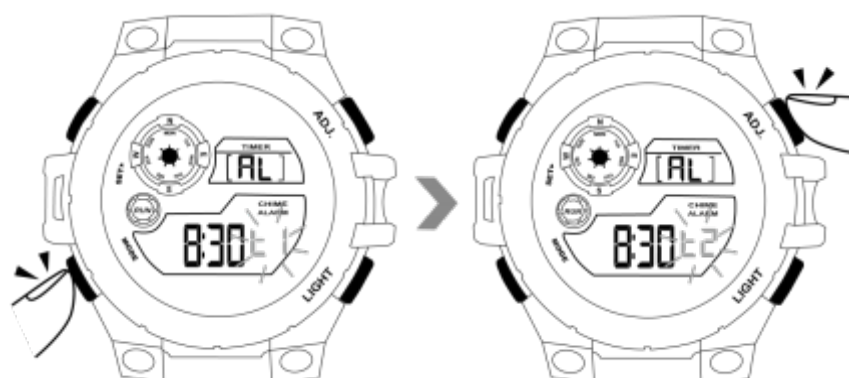

4.1.5 Appuyez une fois sur le bouton SET pour enregistrer le réglage.

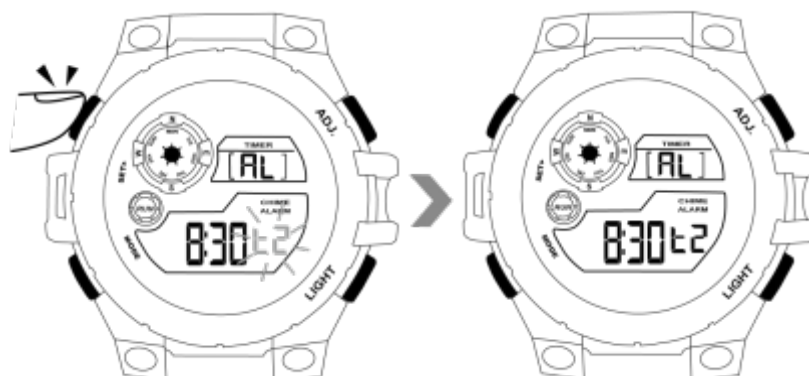

4.1.6 Appuyez une fois sur le bouton MODE pour quitter le mode de réglage de l'alarme.



## 4.2 Activer / désactiver l'alarme

En mode de réglage de l'alarme, appuyez sur le bouton ADJ pour activer ou désactiver l'alarme.

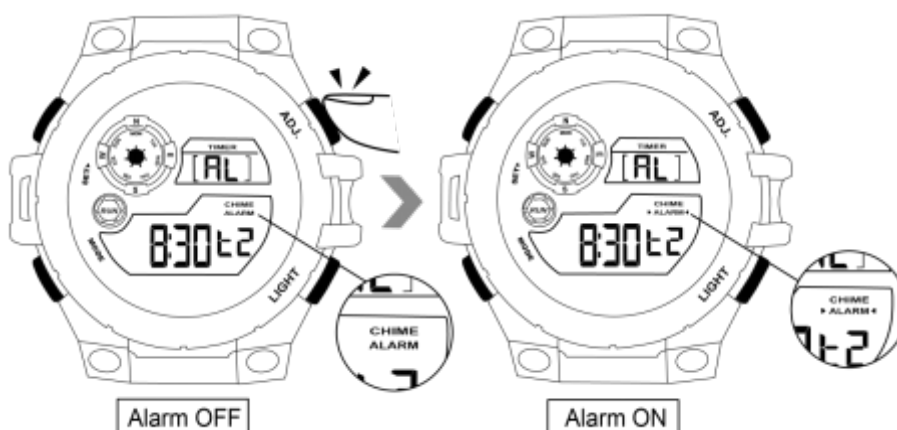

< Remarque >:

1. Le son de l'alarme durerait 20 secondes.
2. Vous pouvez appuyer sur n'importe quel bouton de la montre pour arrêter le son de l'alarme.
3. L'alarme est définie par défaut pour tous les jours.

## V. Activer / désactiver la fonction de carillon horaire

5.1 En mode de réglage de l'alarme, appuyez sur la touche ADJ pour activer / désactiver la fonction de carillon horaire.

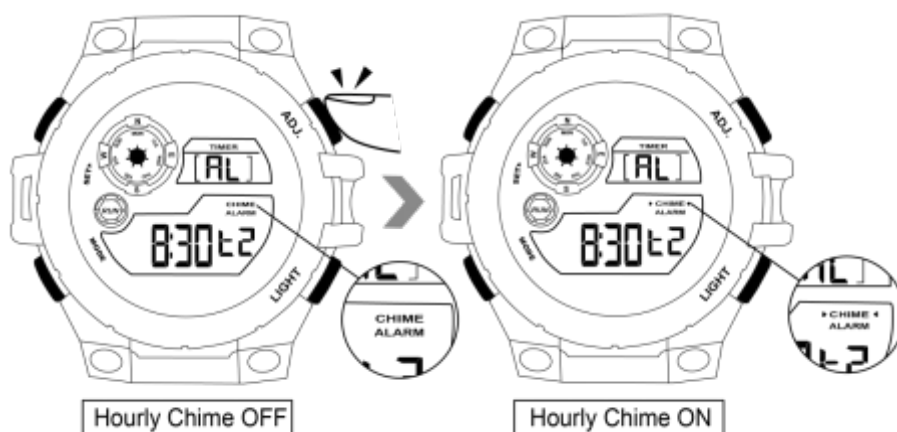

## VI. Compte à rebours

6.1 En mode d'affichage de l'heure locale, appuyez 3 fois sur le bouton MODE pour passer en mode compte à rebours.

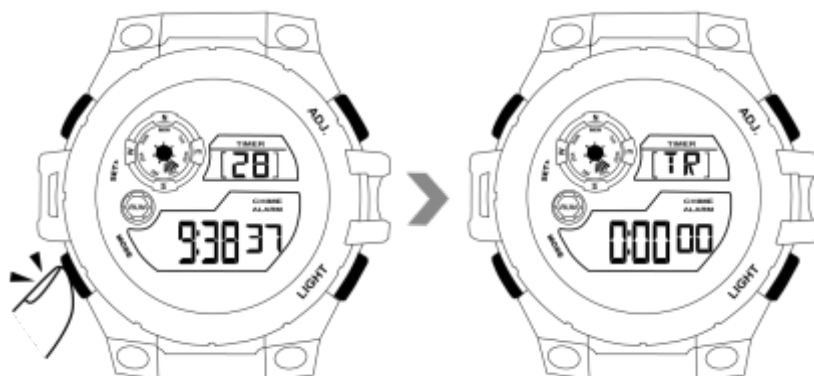

6.2 Maintenez le bouton SET enfoncé jusqu'à ce que le chiffre des heures clignote, puis appuyez sur le bouton ADJ pour régler l'heure.

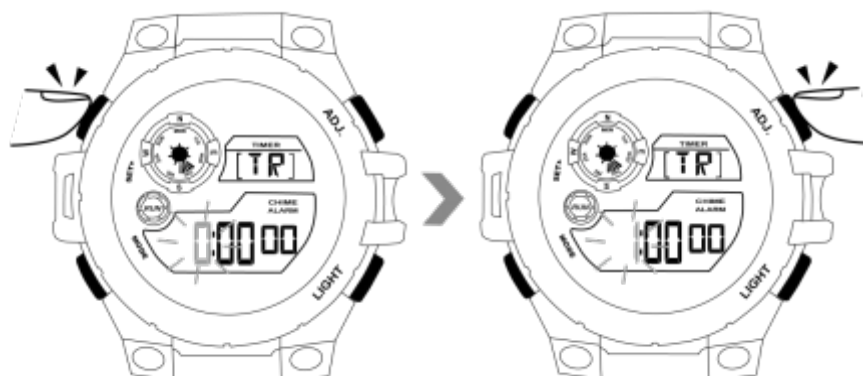

6.3 Appuyez une fois sur le bouton MODE, le chiffre des minutes commence à clignoter, puis appuyez sur le bouton ADJ pour régler les minutes.

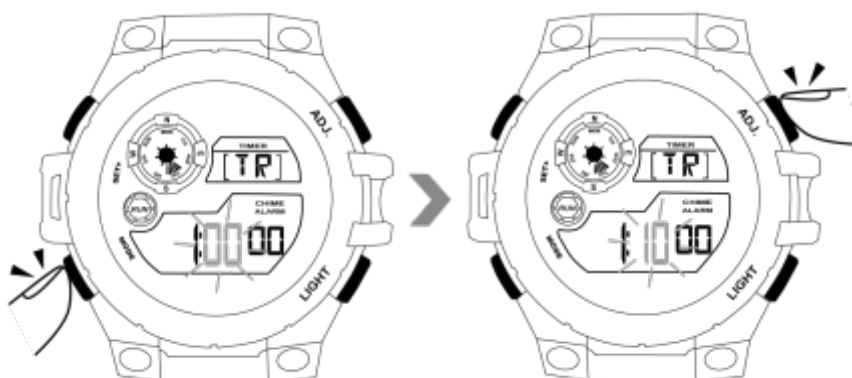

6.4 Appuyez à nouveau sur le bouton MODE, vous verrez le chiffre des secondes commencer à clignoter, puis appuyez sur le bouton ADJ pour régler les secondes.

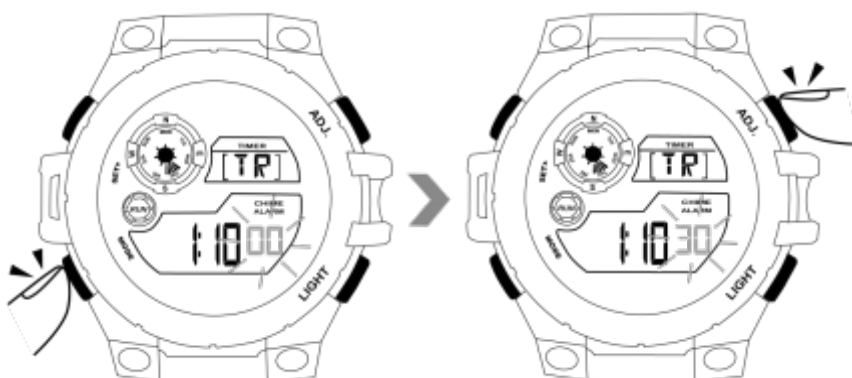

6.5 Appuyez une fois sur le bouton SET pour enregistrer le réglage.

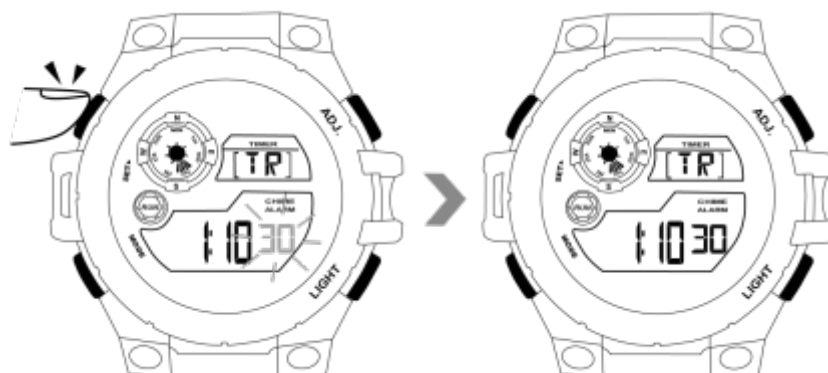

6.6 Appuyez sur le bouton ADJ pour commencer le compte à rebours.



6.7 Appuyez à nouveau sur le bouton ADJ pour arrêter le compte à rebours.



6.8 Appuyez une fois sur le bouton MODE pour quitter le compte à rebours.

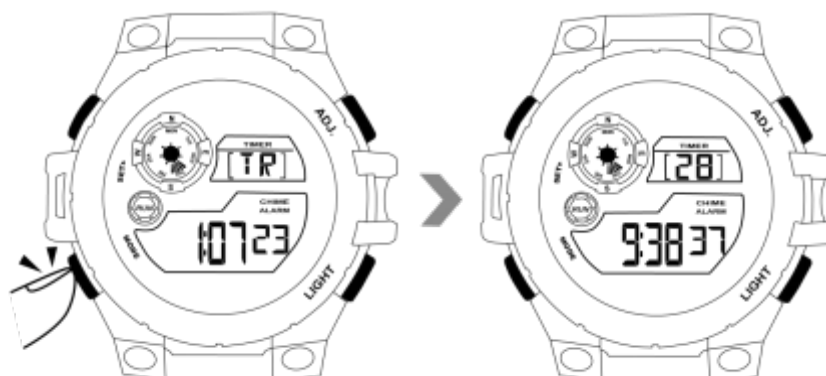

*<Remarque>: Lorsque le compte à rebours est terminé, la montre sonne pendant 10 secondes, puis revient au début.*

## VII. Rétro-éclairage

Appuyez sur le bouton LIGHT pour allumer le rétro-éclairage électroluminescent. Le rétroéclairage s'éteindra automatiquement au bout de 3 secondes environ.





## VIII. Réglage de l'heure pour l'autre fuseau horaire

8.1 En mode d'affichage de l'heure locale, appuyez 4 fois sur le bouton MODE pour passer au mode d'affichage de l'autre fuseau horaire.

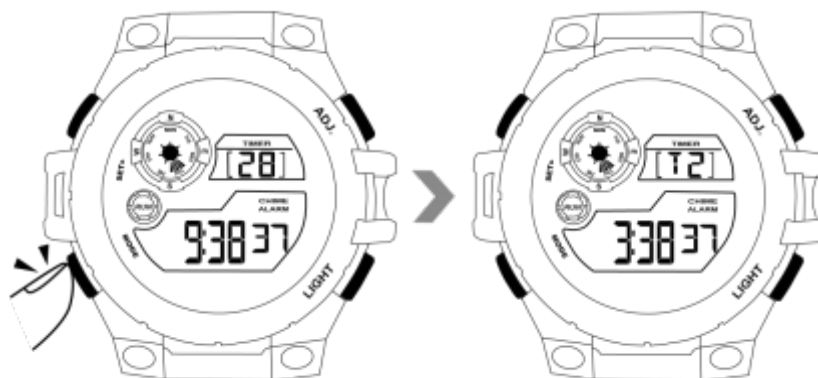

8.2 Maintenez le bouton SET enfoncé jusqu'à ce que le chiffre des heures clignote, puis appuyez sur le bouton ADJ pour régler l'heure.

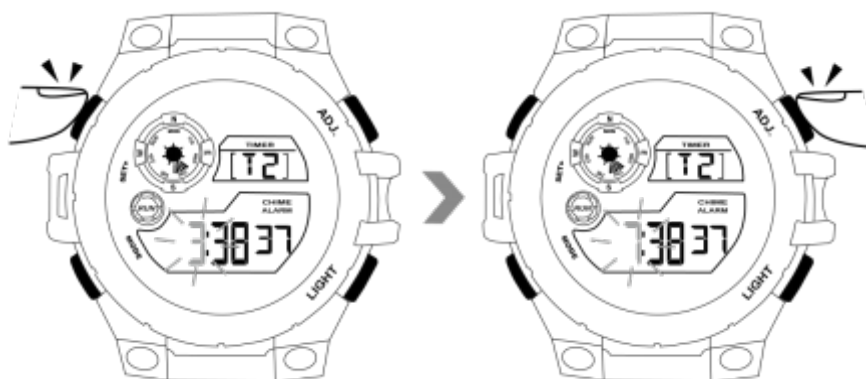

8.3 Appuyez une fois sur le bouton MODE, le chiffre des minutes commence à clignoter, puis appuyez sur le bouton ADJ pour régler les minutes.

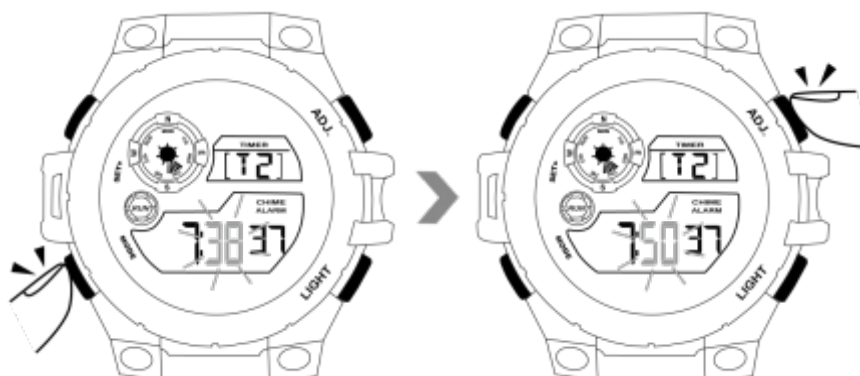

8.4 Appuyez sur le bouton SET pour enregistrer le réglage.

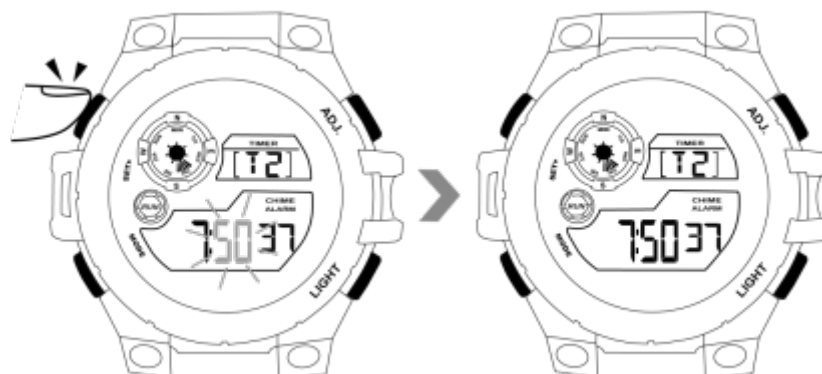

8.5 Appuyez une fois sur le bouton MODE pour quitter le mode d'affichage de l'autre fuseau horaire.

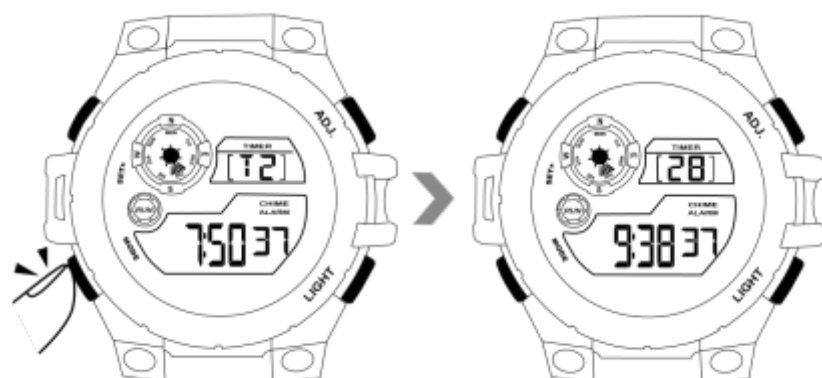

## IX. Vérification du mois et de la date

En mode d'affichage de l'heure locale, maintenez le bouton ADJ enfoncé pour vérifier le mois et la date.



## X. Vérifier l'heure actuelle dans l'autre fuseau horaire

En mode d'affichage de l'heure locale, appuyez 4 fois sur la touche MODE pour vérifier l'heure actuelle dans l'autre fuseau horaire.

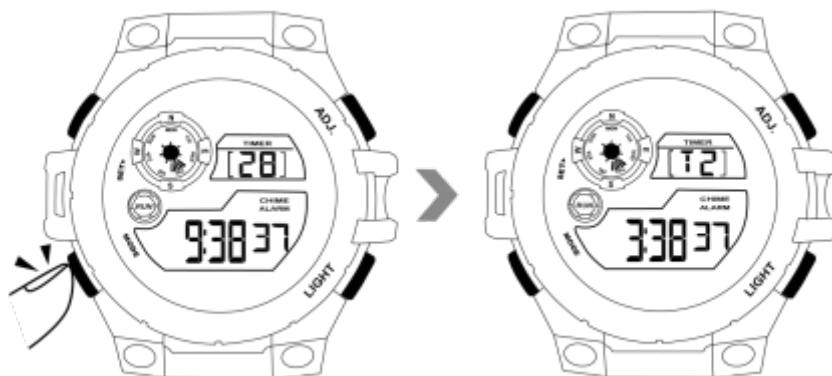

<La fin>

# Guida Utente

Numero di modello: W60 / W61 / W62

## I. Panoramica del Prodotto

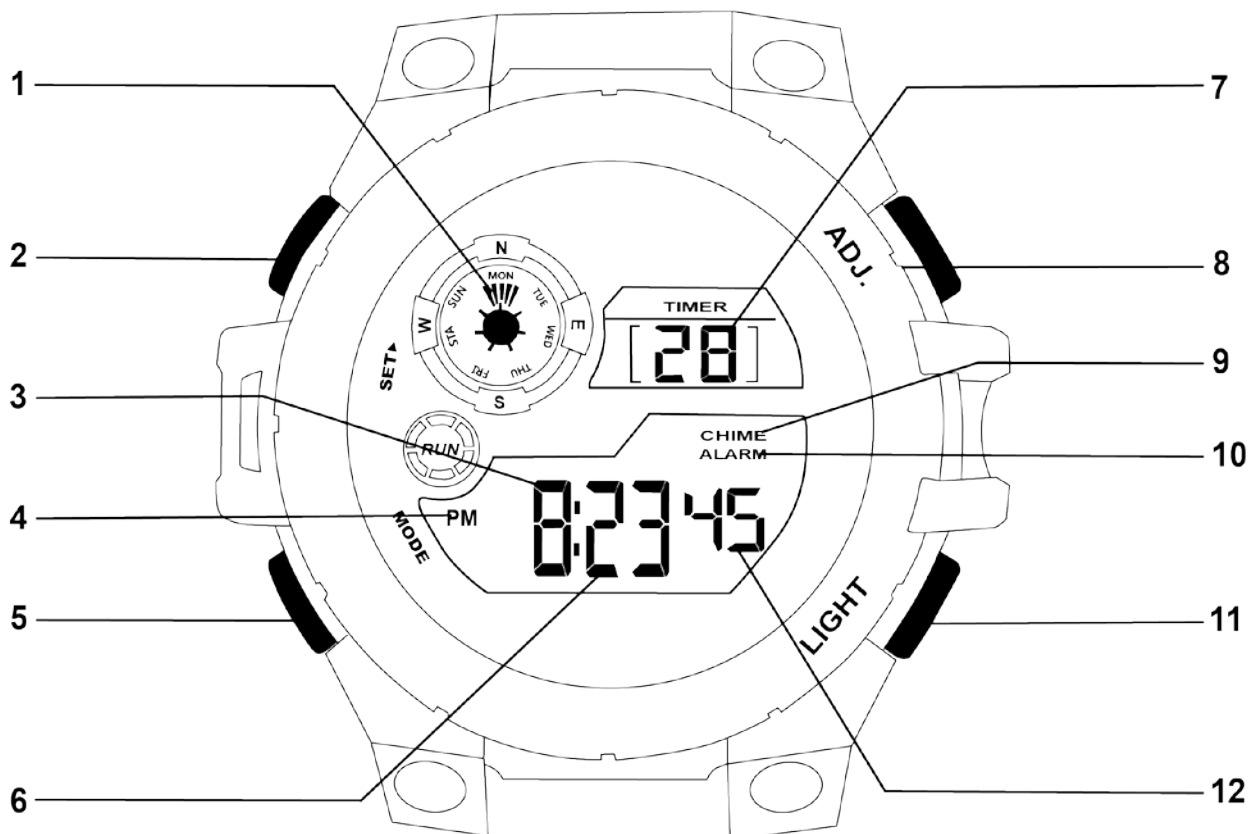

1. Giorno

2. Imposta il pulsante

3. Ora

4. Indicatore PM

5. Pulsante Modalità

6. Minuta

7. Data

8. Pulsante ADJ

9. Indicatore di segnale orario

10. Indicatore di allarme

11. Pulsante luce

12. Seconde

## II. Impostazione ora locale

2.1 Nella modalità di visualizzazione dell'ora locale, tenere premuto il pulsante SET fino a quando la cifra dei secondi lampeggia, quindi premere il tasto ADJ per cancellare la cifra dei secondi oppure saltare al passaggio successivo.



2.2 Premere una volta il pulsante MODE, vedrete che la cifra dell'ora inizia a lampeggiare, quindi premere il tasto ADJ per impostare l'ora.



2.3 Premere nuovamente il pulsante MODE, vedrete che la cifra dei minuti inizia a lampeggiare, quindi premere il tasto ADJ per impostare i minuti.



2.4 Premi nuovamente il pulsante MODE, vedrai lampeggiare la cifra del mese, quindi premi il tasto ADJ per impostare il mese.

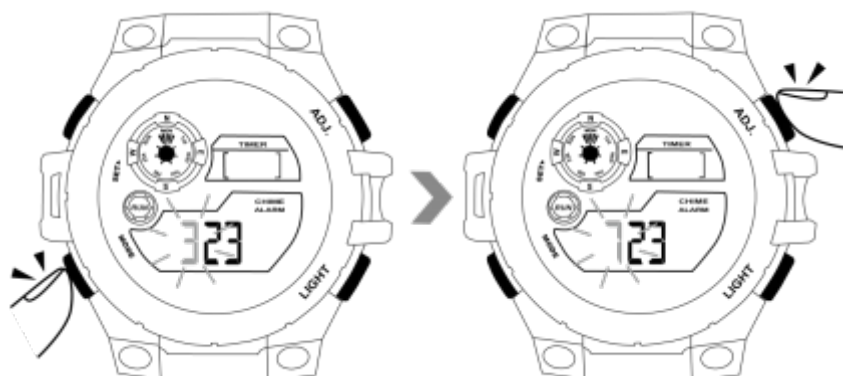

2.5 Premere nuovamente il pulsante MODE, vedrete che la cifra della data inizia a lampeggiare, quindi premere il tasto ADJ per impostare la data.

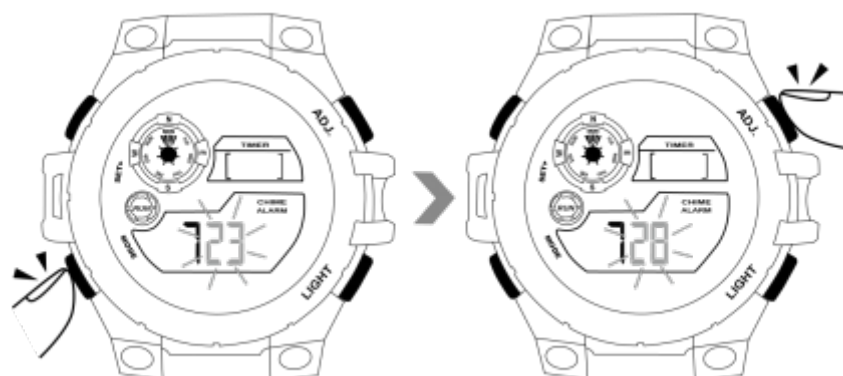

2.6 Premi ancora una volta il pulsante MODE, vedrai che l'indicatore del giorno inizia a lampeggiare, quindi premi il tasto ADJ per impostare il giorno.

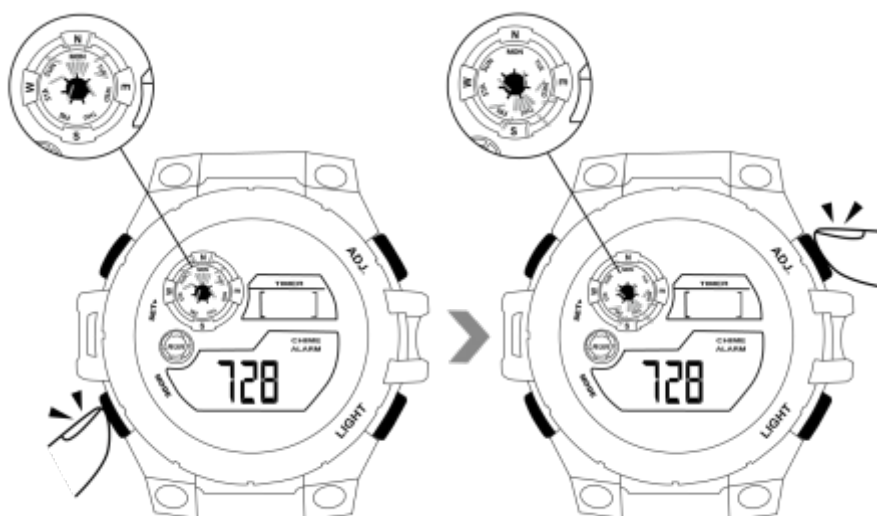

2.7 Premere di nuovo il pulsante MODE, vedrete che l'indicatore della cifra in formato ora inizia a lampeggiare, quindi premere il tasto ADJ per scegliere il formato 12 o 24 ore.

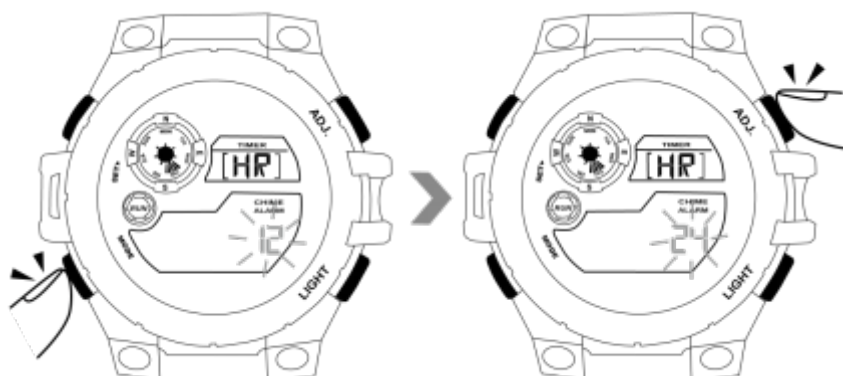

2.8 Premere il pulsante SET una volta per salvare tutte le impostazioni, l'orologio tornerà alla modalità di visualizzazione dell'ora locale.

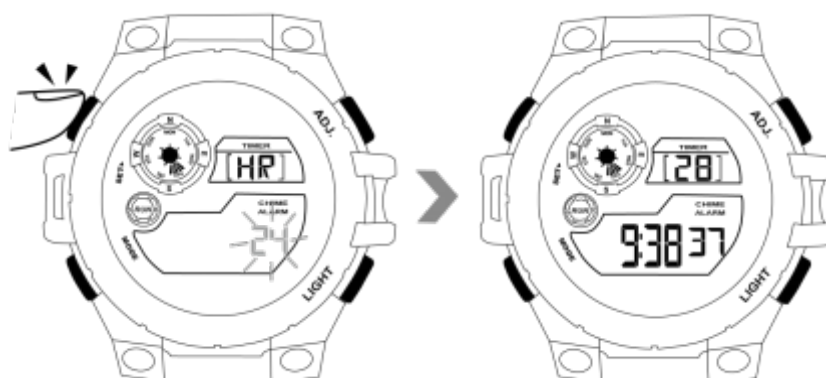

### III. Modalità cronometro

3.1 Nella modalità di visualizzazione dell'ora locale, premere una volta il pulsante MODE per accedere alla modalità cronometro.

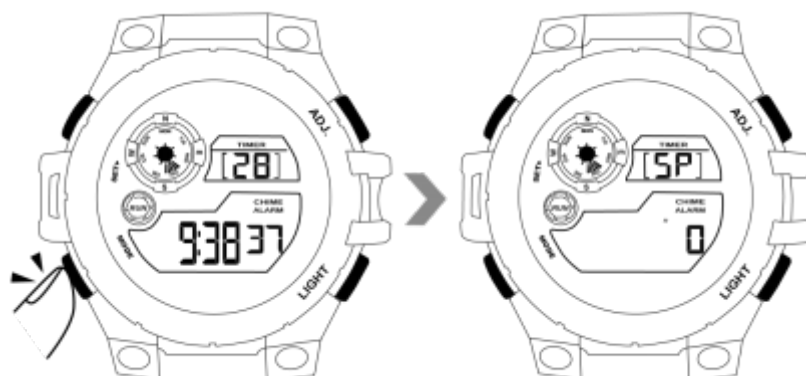

3.2 Premere il tasto ADJ per iniziare il cronometraggio.



3.3 Premere di nuovo il tasto ADJ per fermare il cronometraggio.



3.4 Premere il tasto SET per cancellare.

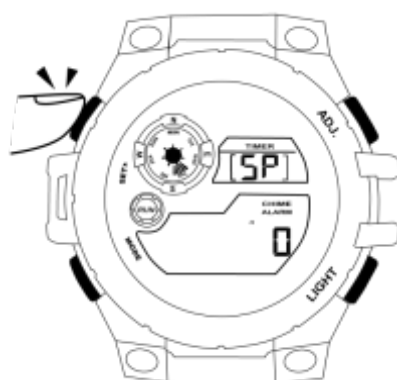



3.5 Premere una volta il pulsante MODE per uscire dalla modalità cronometro.

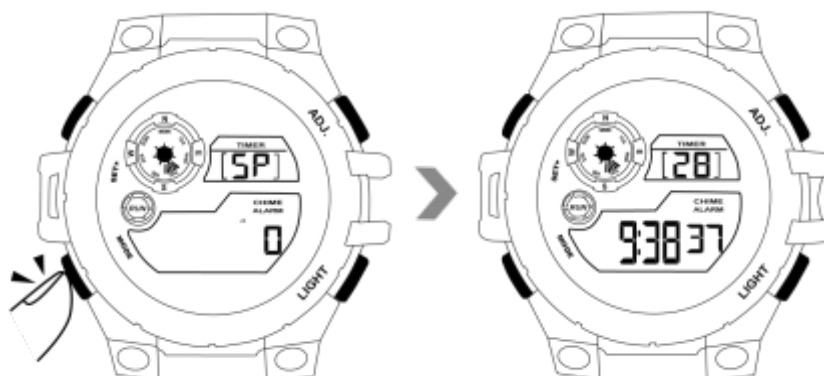

<Nota>:

1. L'intervallo di tempo del cronometro è compreso tra 0'00 "00 e 23: 59'59".
2. Se non si arresta il cronometrando, il cronometro continuerà a cronometrare e inizierà il cronometrando da 0'0"00 anche se il cronometro è superiore a 24 ore e si è usciti dalla modalità cronometro.

## IV. Allarme

### 4.1 Imposta un allarme

4.1.1 Nella modalità di visualizzazione dell'ora locale, premere due volte il pulsante MODE per accedere alla modalità di impostazione della sveglia.

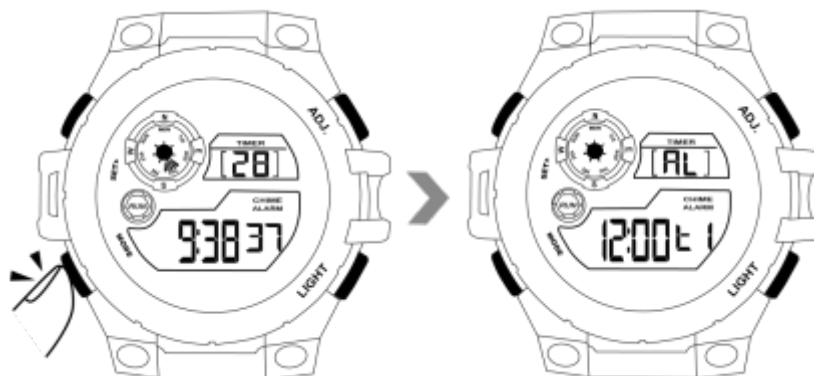

4.1.2 Tenere premuto il pulsante SET fino a quando le cifre dell'ora lampeggiano, quindi premere il tasto ADJ per impostare l'ora.



4.1.3 Premere una volta il pulsante MODE, vedrete che la cifra dei minuti inizia a lampeggiare, quindi premere il tasto ADJ per impostare i minuti.



4.1.4 Premere nuovamente il pulsante MODE, l'indicatore della cifra del fuso orario inizia a lampeggiare, quindi premere il tasto ADJ per selezionare il fuso orario. **Nota: L1 è l'allarme per il fuso orario locale, L2 è l'allarme per l'altro fuso orario.**

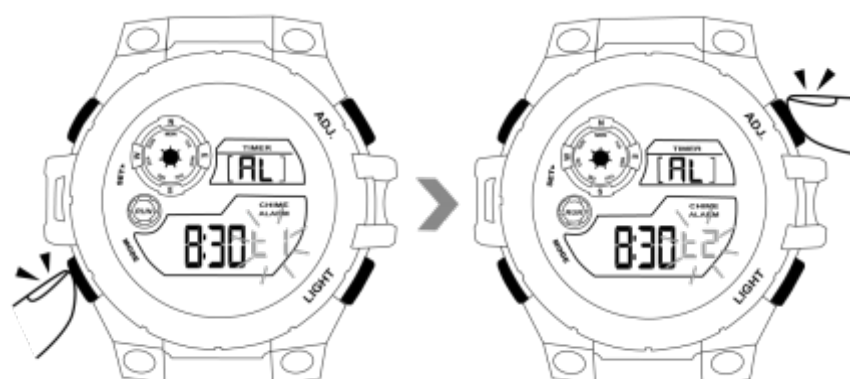

4.1.5 Premere il pulsante SET una volta per salvare le impostazioni.

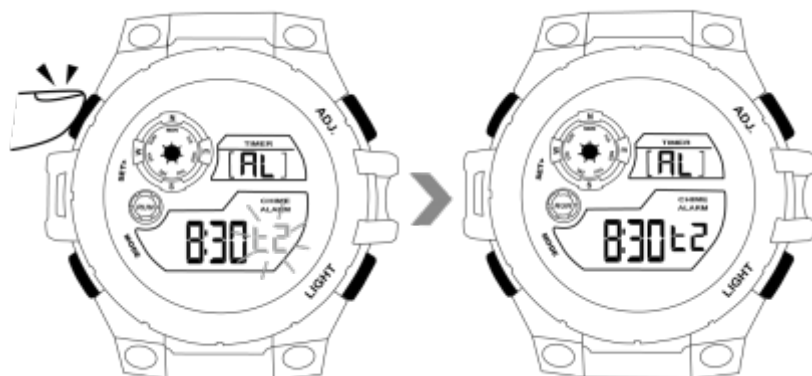

4.1.6 Premere una volta il pulsante MODE per uscire dalla modalità di impostazione della sveglia.

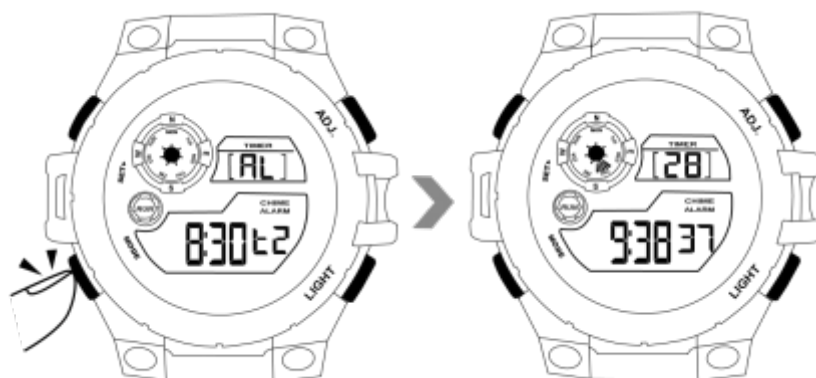

## 4.2 Attiva / disattiva allarme

Nella modalità di impostazione della sveglia, premere il tasto ADJ per accendere o spegnere la sveglia.

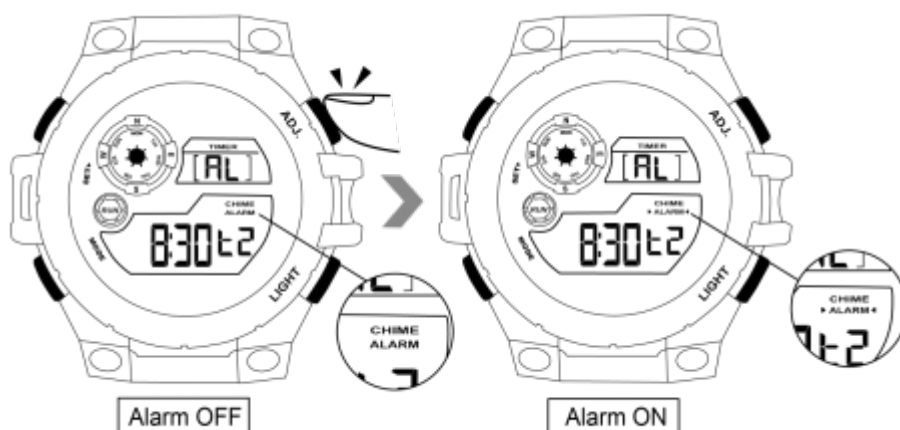

<Nota>:

1. Il suono della sveglia durerà per 20 secondi.
2. È possibile premere qualsiasi pulsante sull'orologio per interrompere il suono della sveglia.
3. L'allarme è impostato di default per tutti i giorni.

## V. Attiva / Disattiva la funzione di avviso orario

5.1 Nella modalità di impostazione della sveglia, premere il tasto ADJ per attivare / disattivare la funzione del segnale orario.



## VI. Timer conto alla rovescia

6.1 Nella modalità di visualizzazione dell'ora locale, premere il pulsante MODE per 3 volte per accedere alla modalità conto alla rovescia del timer.



6.2 Tenere premuto il pulsante SET fino a quando le cifre dell'ora lampeggiano, quindi premere il tasto ADJ per impostare l'ora.

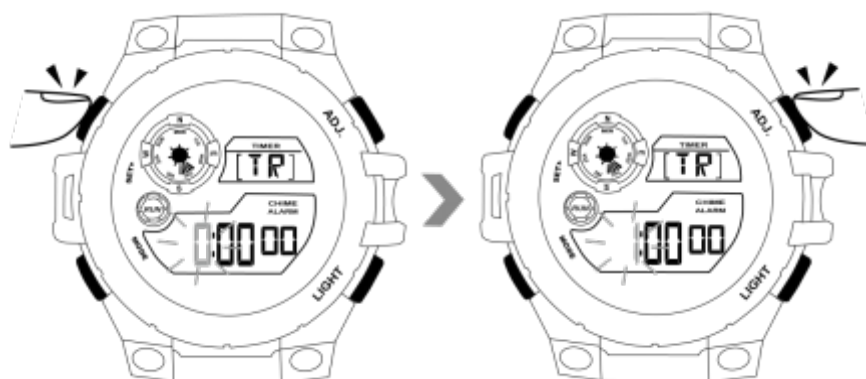

6.3 Premere una volta il pulsante MODE, vedrete che la cifra dei minuti inizia a lampeggiare, quindi premere il tasto ADJ per impostare i minuti.

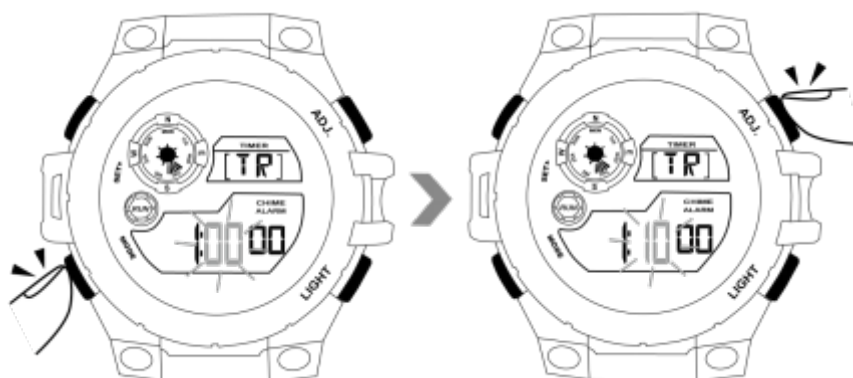

6.4 Premere nuovamente il pulsante MODE, vedrai lampeggiare la cifra dei secondi, quindi premere il tasto ADJ per impostare i secondi.

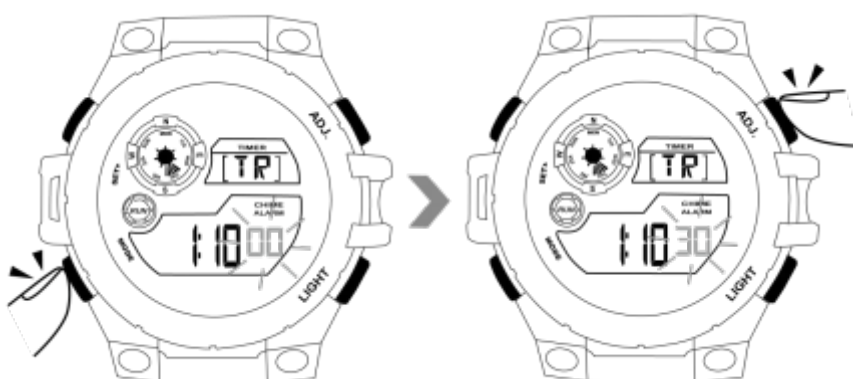

6.5 Premere il pulsante SET una volta per salvare le impostazioni.

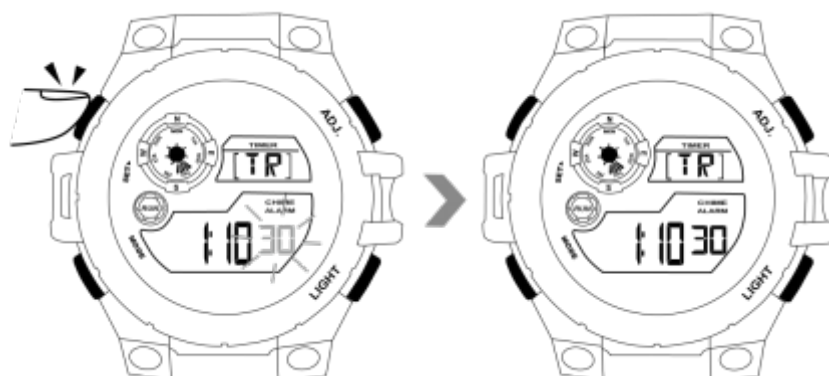

6.6 Premere il pulsante ADJ per iniziare il conto alla rovescia.



6.7 Premere di nuovo il tasto ADJ per interrompere il conto alla rovescia.



6.8 Premere una volta il pulsante MODE per uscire dal conto alla rovescia del timer.

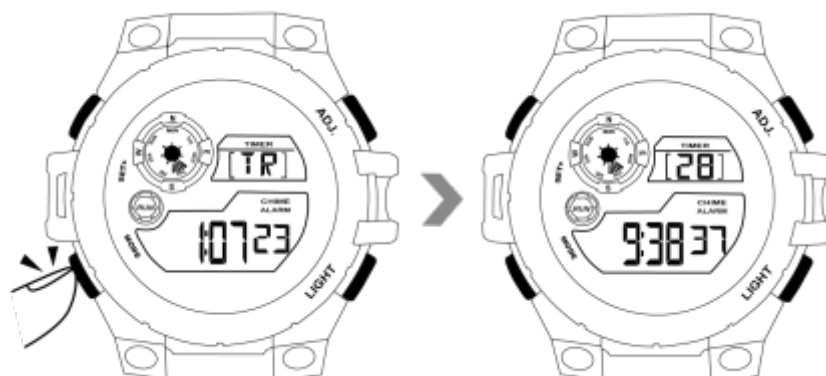

*<Nota>: Al termine del conto alla rovescia, l'orologio suona per 10 secondi e poi torna all'inizio.*

## VII. Luce posteriore

Premere il pulsante LIGHT per accendere la retroilluminazione elettroluminescente. La retroilluminazione si spegne automaticamente in circa 3 secondi.



## VIII. Impostazione dell'ora per l'altro fuso orario

8.1 Nella modalità di visualizzazione dell'ora locale, premere il pulsante MODE per 4 volte per accedere all'altra modalità di visualizzazione del fuso orario.

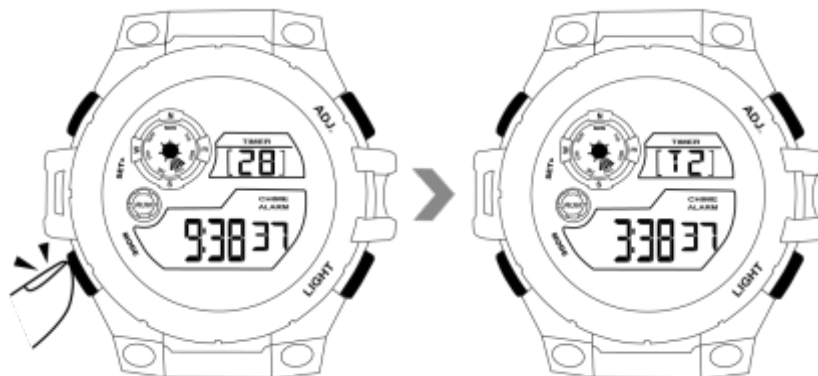

8.2 Tenere premuto il pulsante SET fino a quando le cifre dell'ora lampeggiano, quindi premere il tasto ADJ per impostare l'ora.

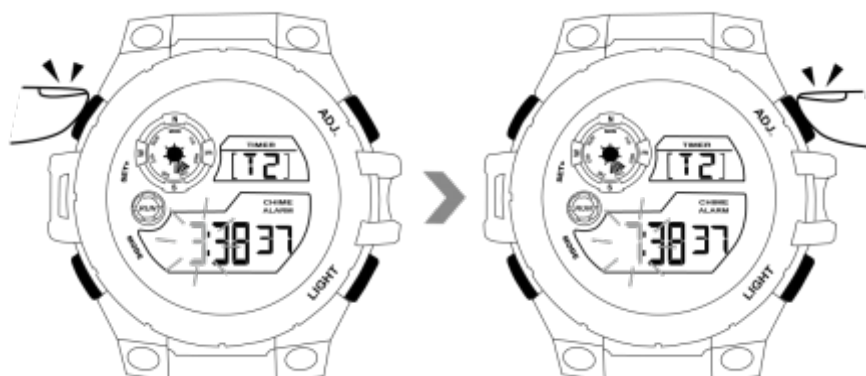

8.3 Premere una volta il pulsante MODE, vedrete che la cifra dei minuti inizia a lampeggiare, quindi premere il tasto ADJ per impostare i minuti.

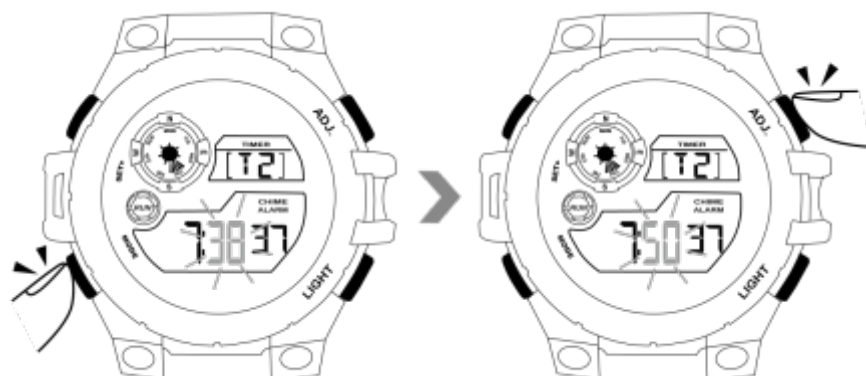



8.4 Premere il tasto SET per salvare le impostazioni.

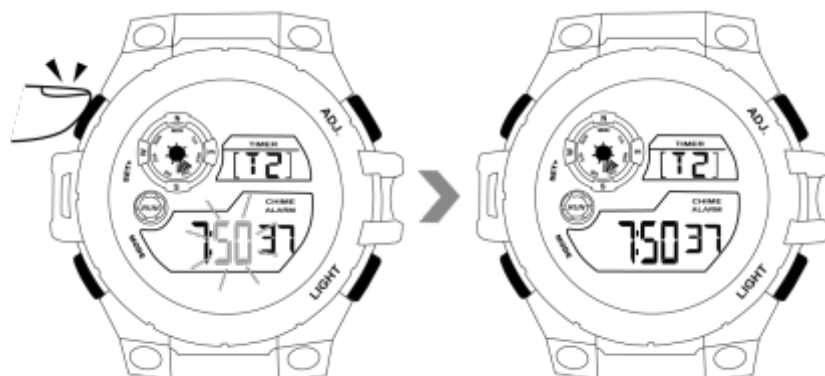

8.5 Premere una volta il pulsante MODE per uscire dall'altra modalità di visualizzazione del fuso orario.

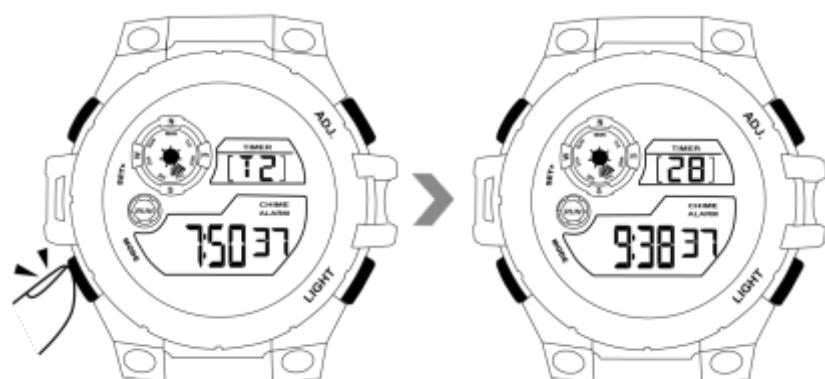

## IX. Controllo mese e data

Nella modalità di visualizzazione dell'ora locale, tenere premuto il tasto ADJ per controllare mese e data.



## X. Controlla l'ora corrente nell'altro fuso orario

Nella modalità di visualizzazione dell'ora locale, premere il pulsante MODE per 4 volte per controllare l'ora corrente nell'altro fuso orario.

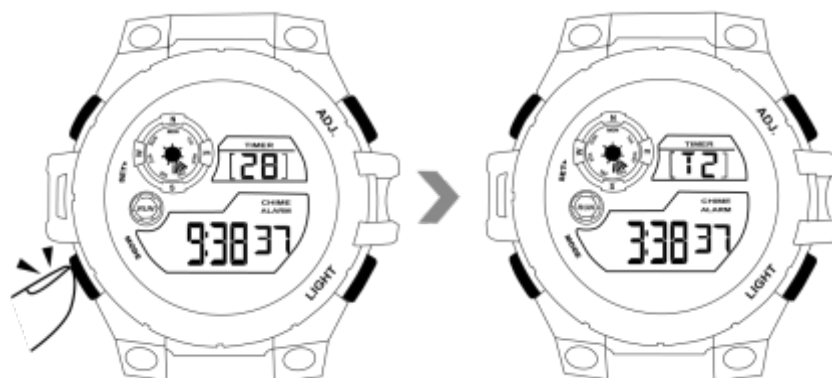

< La fine >

# Guía del Usuario

Número de modelo: W60 / W61 / W62

## I. Visión General del Producto

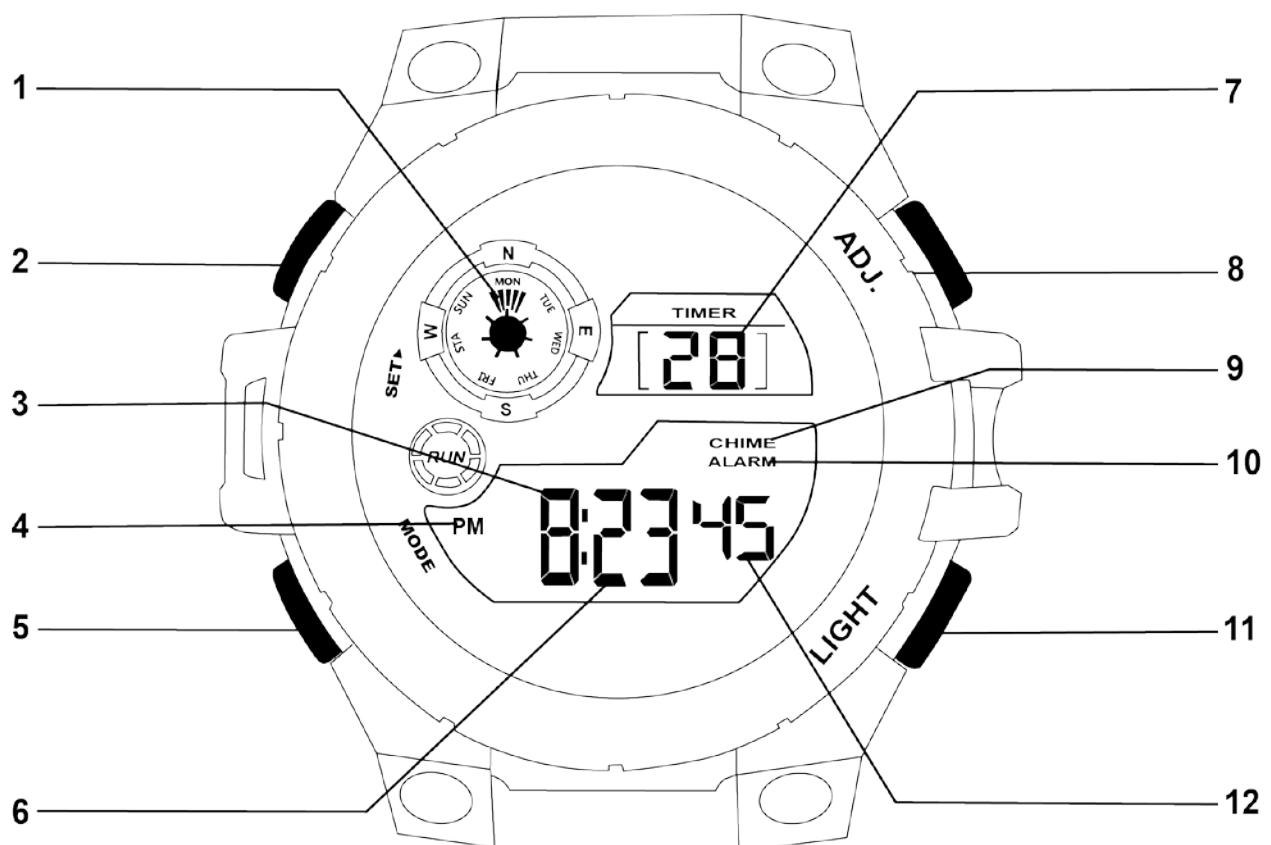

1. Día

2. Botón de ajuste

3. Hora

4. Indicador de PM

5. Botón de modo

6. Minuto

7. Fecha

8. Botón ADJ

9. Indicador de timbre por hora

10. Indicador de alarma

11. Botón de luz

12. Segundos

## II. Configuración de hora local

2.1 En el modo de visualización de la hora local, mantenga presionado el botón SET hasta que vea que el dígito de los segundos está parpadeando, luego presione el botón ADJ para borrar el dígito de los segundos o puede saltar al siguiente paso.



2.2 Presione el botón MODO una vez, verá que el dígito de la hora comienza a parpadear, luego presione el botón AJUSTE para ajustar la hora.



2.3 Presione el botón MODE una vez más, verá que el dígito de los minutos comienza a parpadear, luego presione el botón ADJ para ajustar los minutos.



2.4 Presione el botón MODE una vez más, verá que el dígito del mes comienza a parpadear, luego presione el botón ADJ para configurar el mes.

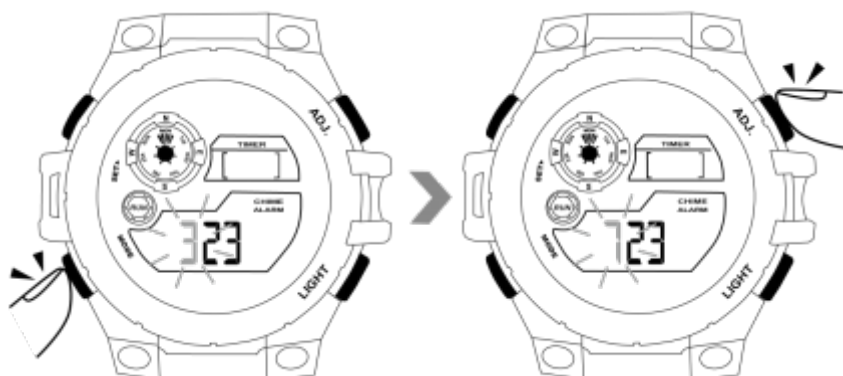

2.5 Presione el botón MODE una vez más, verá que el dígito de la fecha comienza a parpadear, luego presione el botón ADJ para establecer la fecha.

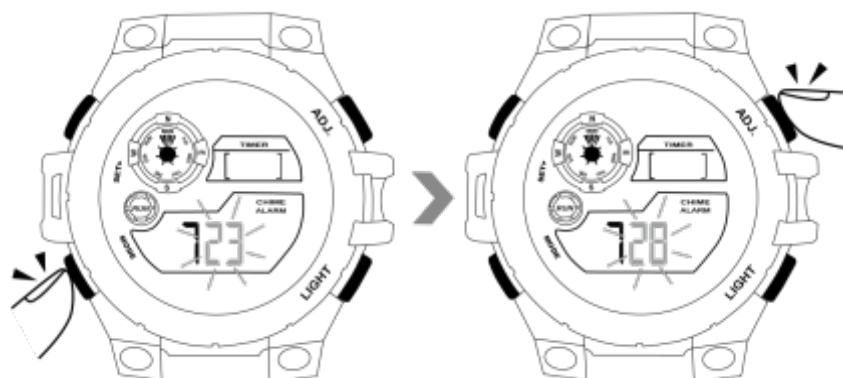

2.6 Presione el botón MODE una vez más, verá que el indicador de día comienza a parpadear, luego presione el botón ADJ para ajustar el día.

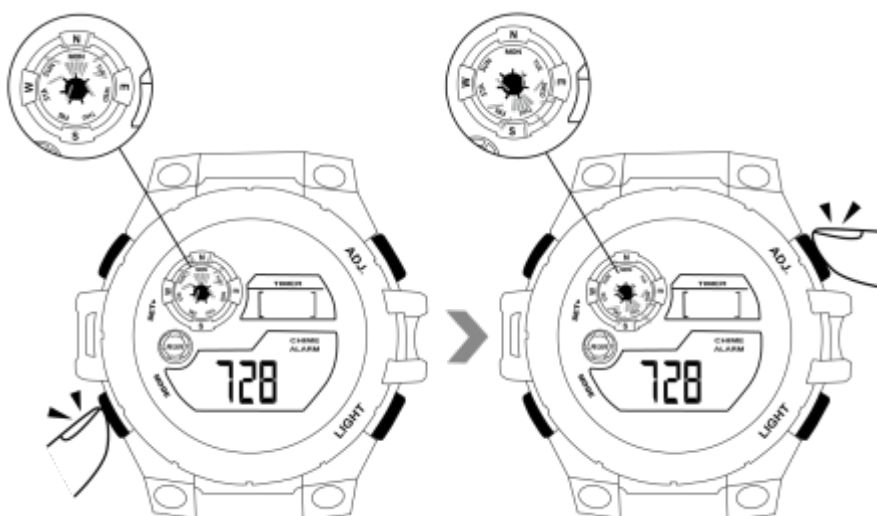

2.7 Presione el botón MODE una vez más, verá que el indicador de dígitos del formato de hora comienza a parpadear, luego presione el botón ADJ para elegir el formato de 12 o 24 horas.

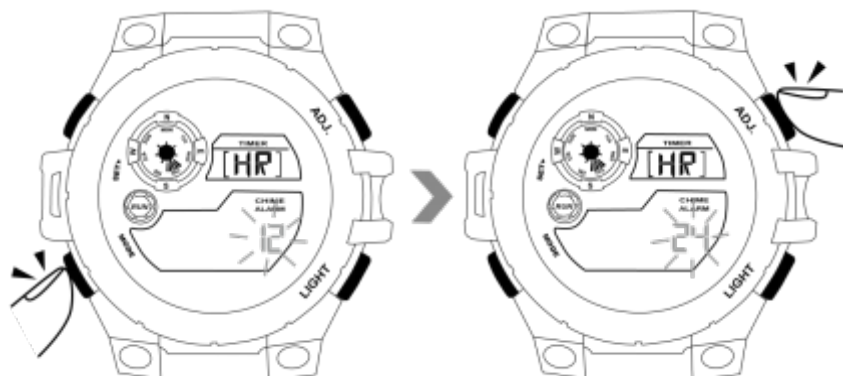

2.8 Presione el botón SET una vez para guardar todos los ajustes, el reloj volverá al modo de visualización de la hora local.

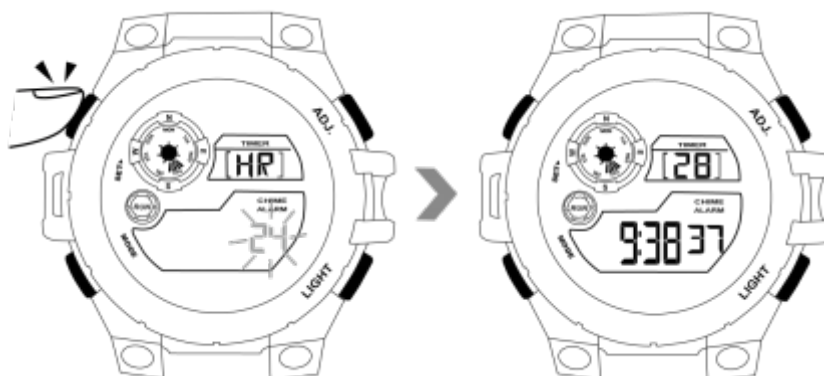

### III. Modo de cronómetro

3.1 En el modo de visualización de la hora local, presione el botón MODE una vez para ingresar al modo de cronómetro.

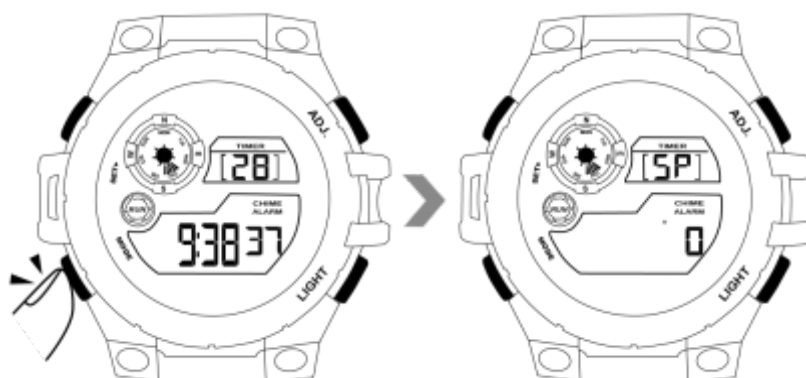

3.2 Presione el botón ADJ para iniciar el cronometraje.



3.3 Presione el botón ADJ otra vez para detener el tiempo.



3.4 Presione el botón SET para borrar.

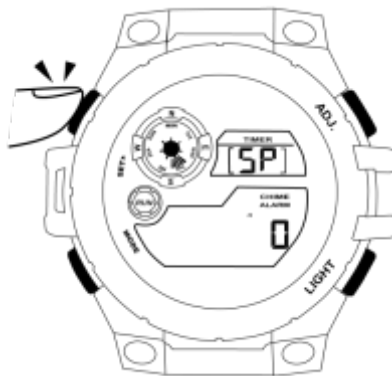

3.5 Presione el botón MODE una vez para salir del modo de cronómetro.

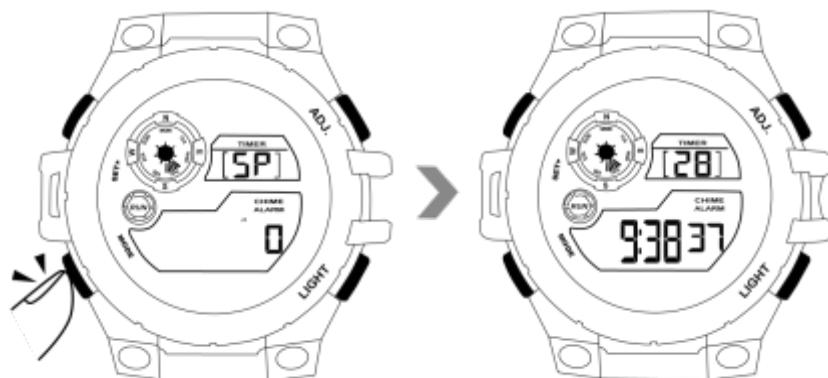

<Nota> :

1. El rango de tiempo del cronómetro es de 0'00 "00 a 23: 59'59".
2. Si no detiene el cronometraje, el cronómetro continuará cronometrando y comenzará a cronometrar desde 0'0"00, incluso cuando el cronometraje haya transcurrido 24 horas y haya salido del modo de cronómetro.

## IV. Alarma

### 4.1 Configurar una alarma

4.1.1 En el modo de visualización de la hora local, presione el botón MODE dos veces para ingresar al modo de configuración de alarma.

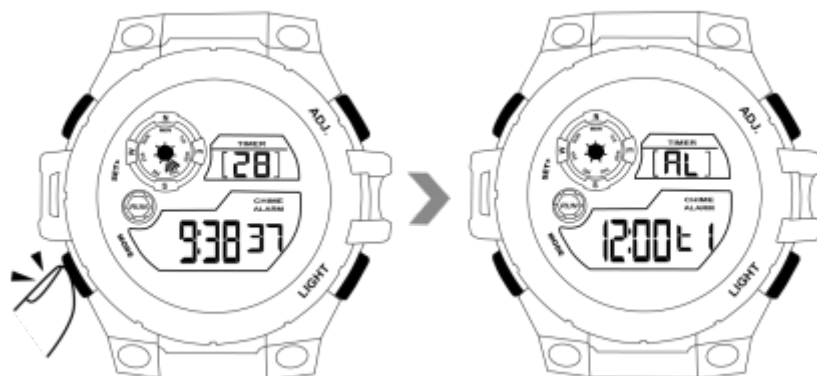



4.1.2 Mantenga presionado el botón SET hasta que vea que el dígito de la hora está parpadeando, luego presione el botón ADJ para ajustar la hora.



4.1.3 Presione el botón MODE una vez, verá que el dígito del minuto comienza a parpadear, luego presione el botón ADJ para ajustar el minuto.



4.1.4 Presione el botón MODE una vez más, verá que el indicador de dígitos de la zona horaria comienza a parpadear, luego presione el botón ADJ para seleccionar la zona horaria.

**Nota: L1 es la alarma para su zona horaria local, L2 es la alarma para la otra zona horaria.**

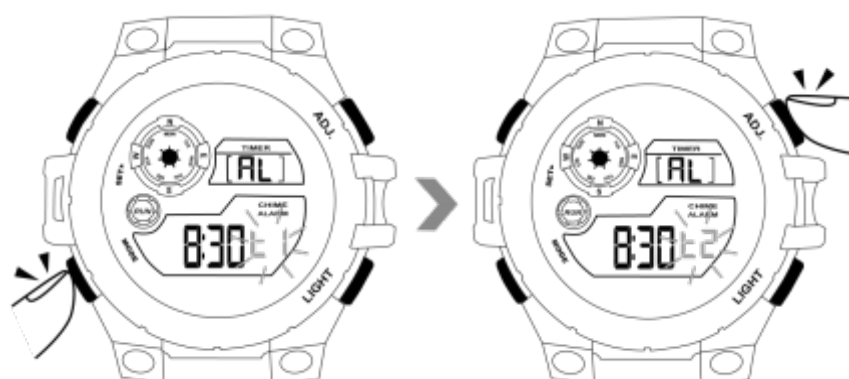

4.1.5 Presione el botón SET una vez para guardar la configuración.

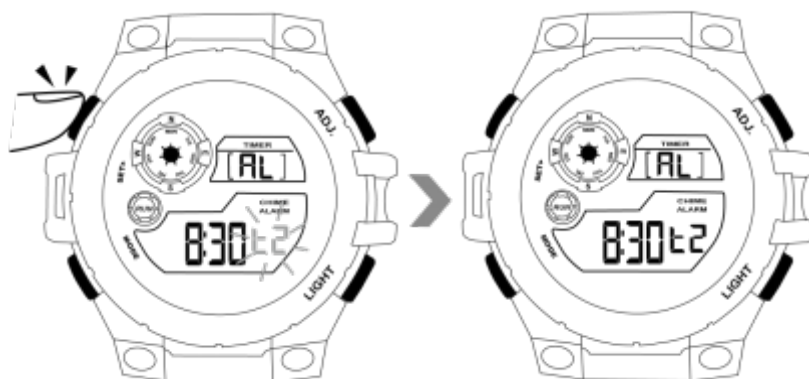

4.1.6 Presione el botón MODE una vez para salir del modo de configuración de alarma.

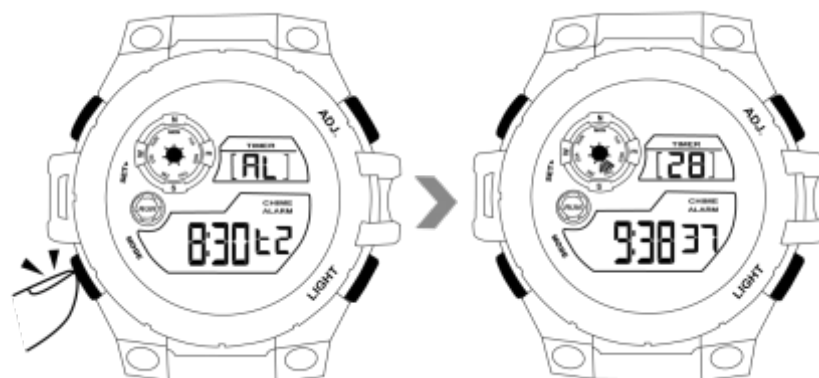

## 4.2 Activar / desactivar la alarma

En el modo de configuración de alarma, presione el botón ADJ para activar o desactivar la alarma.

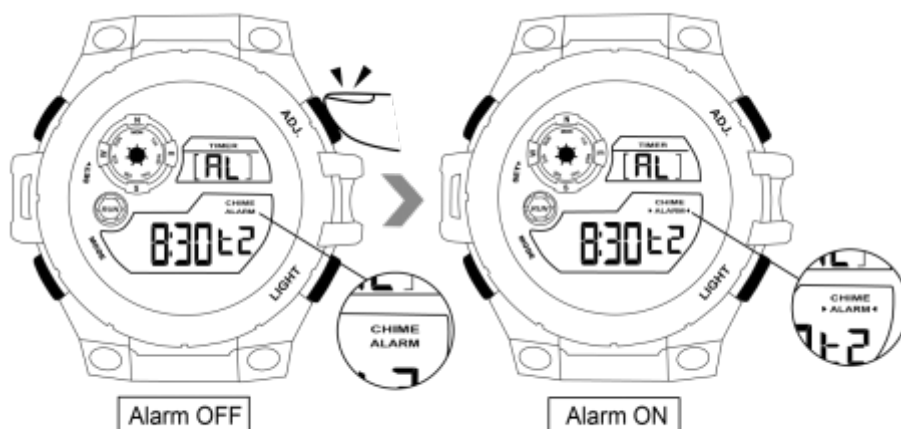

<Nota>:

1. El sonido de la alarma duraría 20 segundos.
2. Puede presionar cualquier botón del reloj para detener el sonido de la alarma.
3. La alarma está configurada por defecto para todos los días.

## V. Activar / desactivar la función de timbre por hora

5.1 En el modo de configuración de alarma, presione el botón ADJ para activar / desactivar la función de timbre por hora.

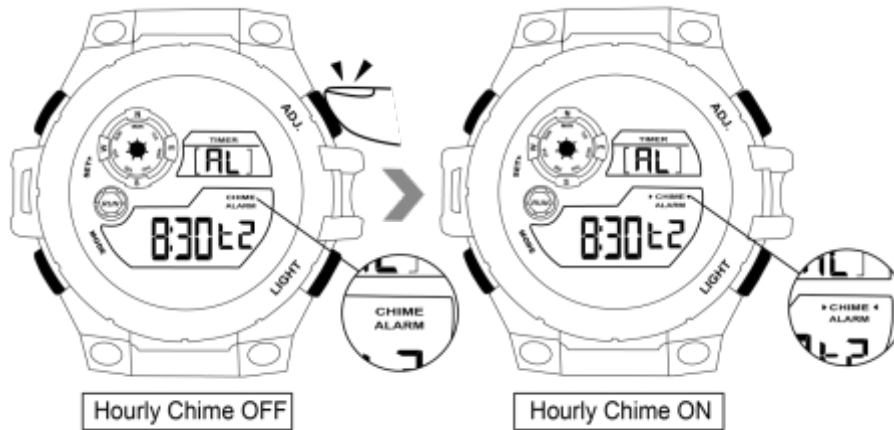

## VI. Temporizador de cuenta regresiva

6.1 En el modo de visualización de la hora local, presione el botón MODE 3 veces para ingresar al modo de cuenta regresiva del temporizador.



6.2 Mantenga presionado el botón SET hasta que vea que el dígito de la hora está parpadeando, luego presione el botón ADJ para ajustar la hora.

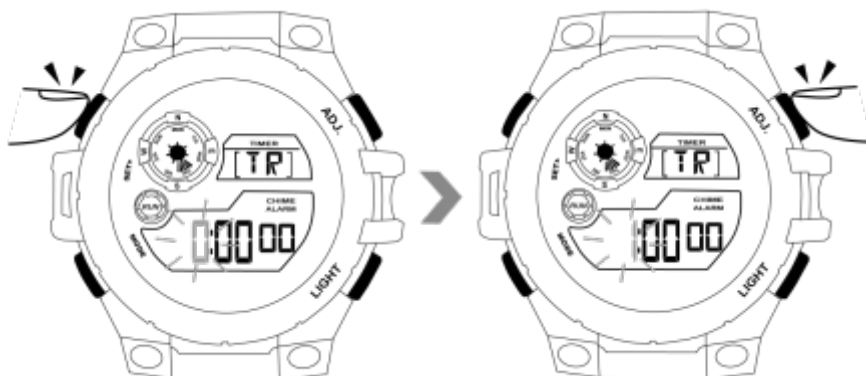

6.3 Presione el botón MODE una vez, verá que el dígito del minuto comienza a parpadear, luego presione el botón ADJ para ajustar el minuto.

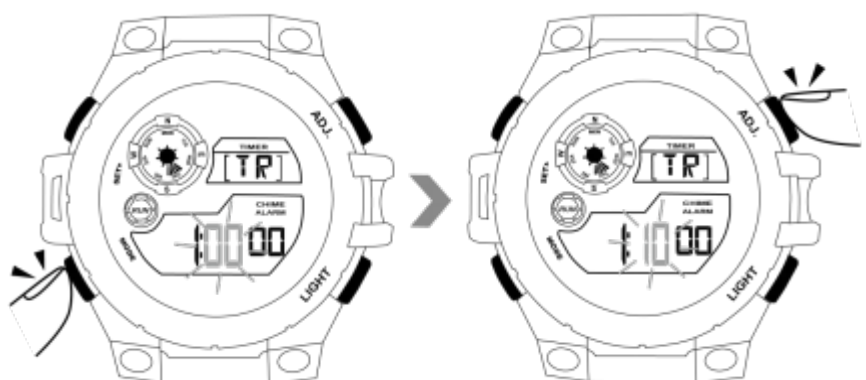

6.4 Presione el botón MODE una vez más, verá que el dígito de los segundos comienza a parpadear, luego presione el botón ADJ para ajustar los segundos.

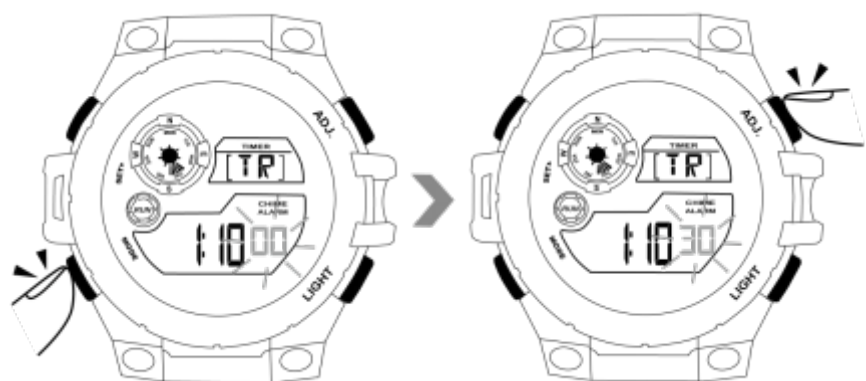

6.5 Presione el botón SET una vez para guardar la configuración.

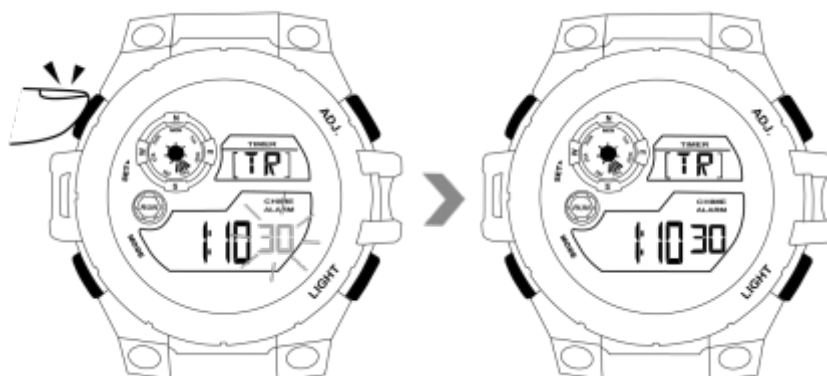

6.6 Presione el botón ADJ para comenzar la cuenta regresiva.



6.7 Presione el botón ADJ otra vez para detener la cuenta regresiva.



6.8 Presione el botón MODE una vez para salir de la cuenta regresiva del temporizador.

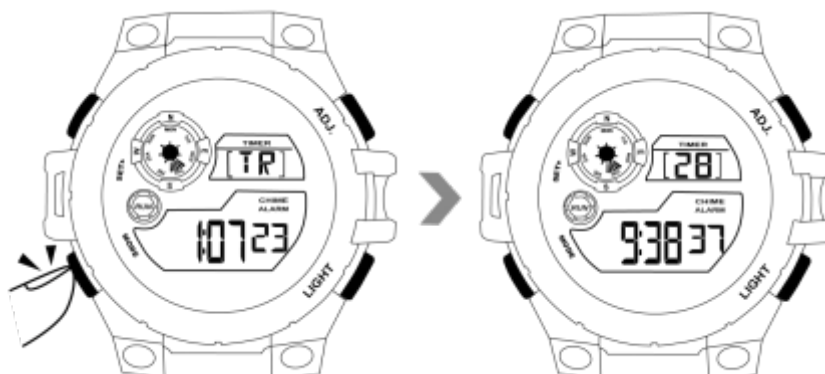

<Nota>: cuando finaliza la cuenta atrás, el reloj sonará durante 10 segundos y luego volverá al inicio.

## VII. Luz de fondo

Presione el botón LIGHT para encender la luz de fondo electroluminiscente. La luz de fondo se apagará automáticamente en unos 3 segundos.



## VIII. Configuración de hora para la otra zona horaria

8.1 En el modo de visualización de la hora local, presione el botón MODE 4 veces para ingresar al otro modo de visualización de la zona horaria.

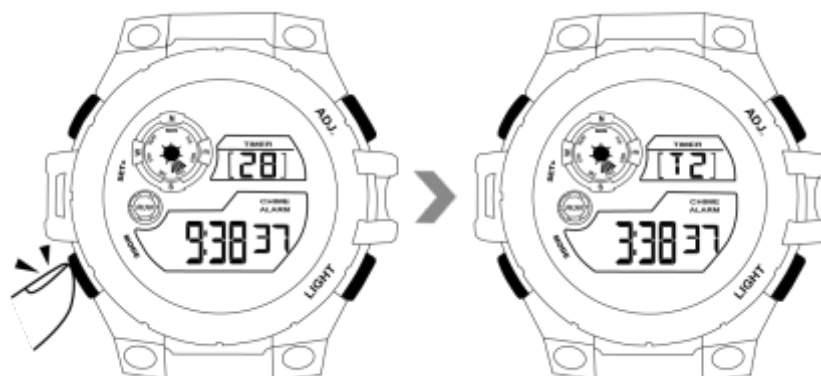

8.2 Mantenga presionado el botón SET hasta que vea que el dígito de la hora está parpadeando, luego presione el botón ADJ para ajustar la hora.

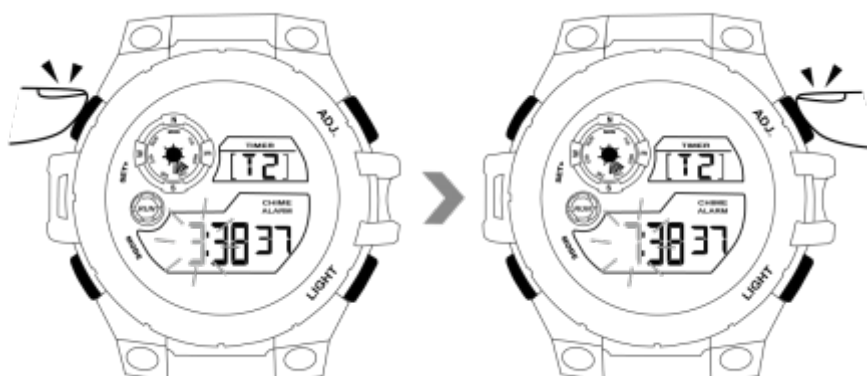

8.3 Presione el botón MODE una vez, verá que el dígito del minuto comienza a parpadear, luego presione el botón ADJ para ajustar el minuto.

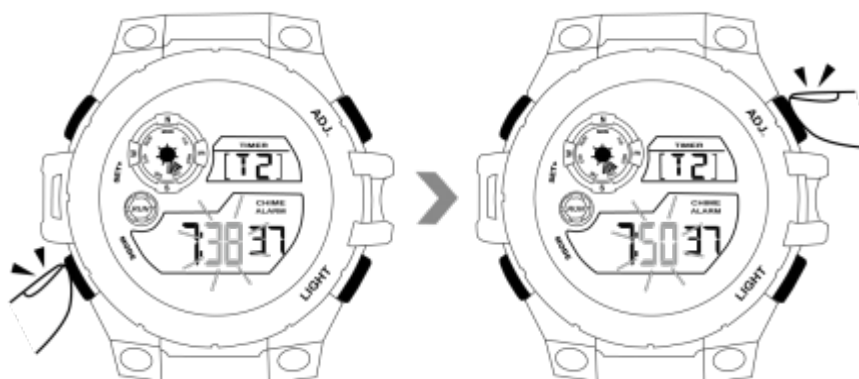

8.4 Presione el botón SET para guardar la configuración.

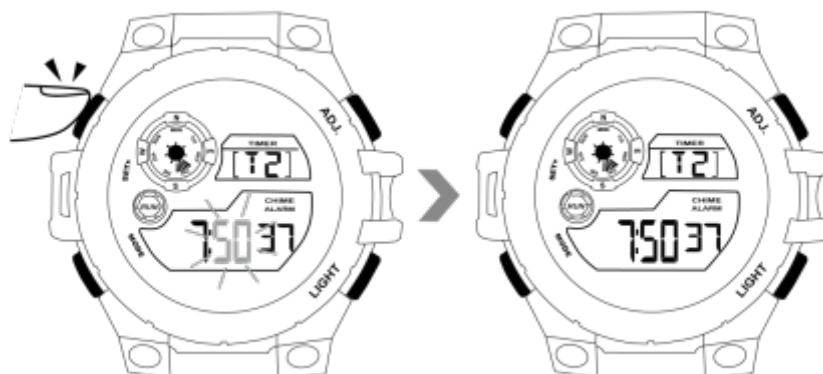

8.5 Presione el botón MODE una vez para salir del otro modo de visualización de zona horaria.

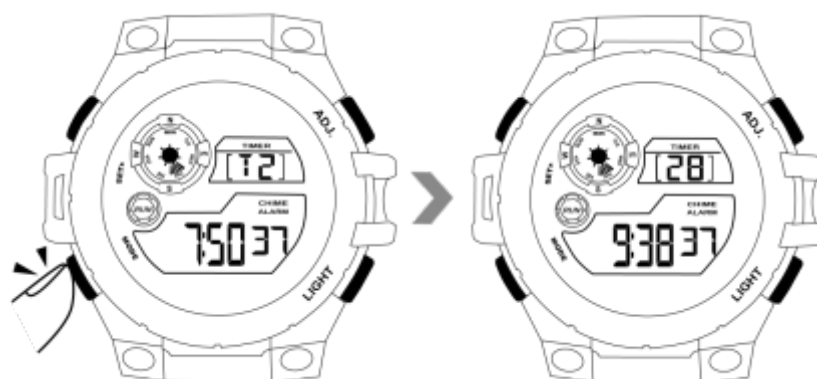

## IX. Mes y fecha de verificación

En el modo de visualización de la hora local, mantenga presionado el botón ADJ para verificar el mes y la fecha.





## X. Verifique la hora actual en la otra zona horaria

En el modo de visualización de la hora local, presione el botón MODE 4 veces para verificar la hora actual en la otra zona horaria.

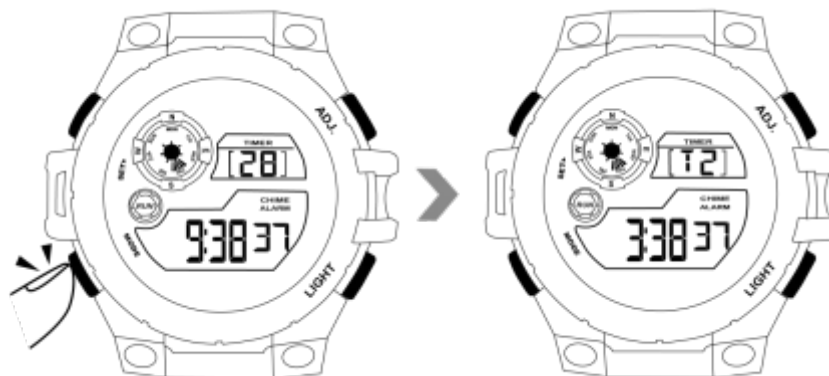

< El fin >

# 取扱説明書

モデル番号: W60 / W61 / W62

## I. 製品の概要

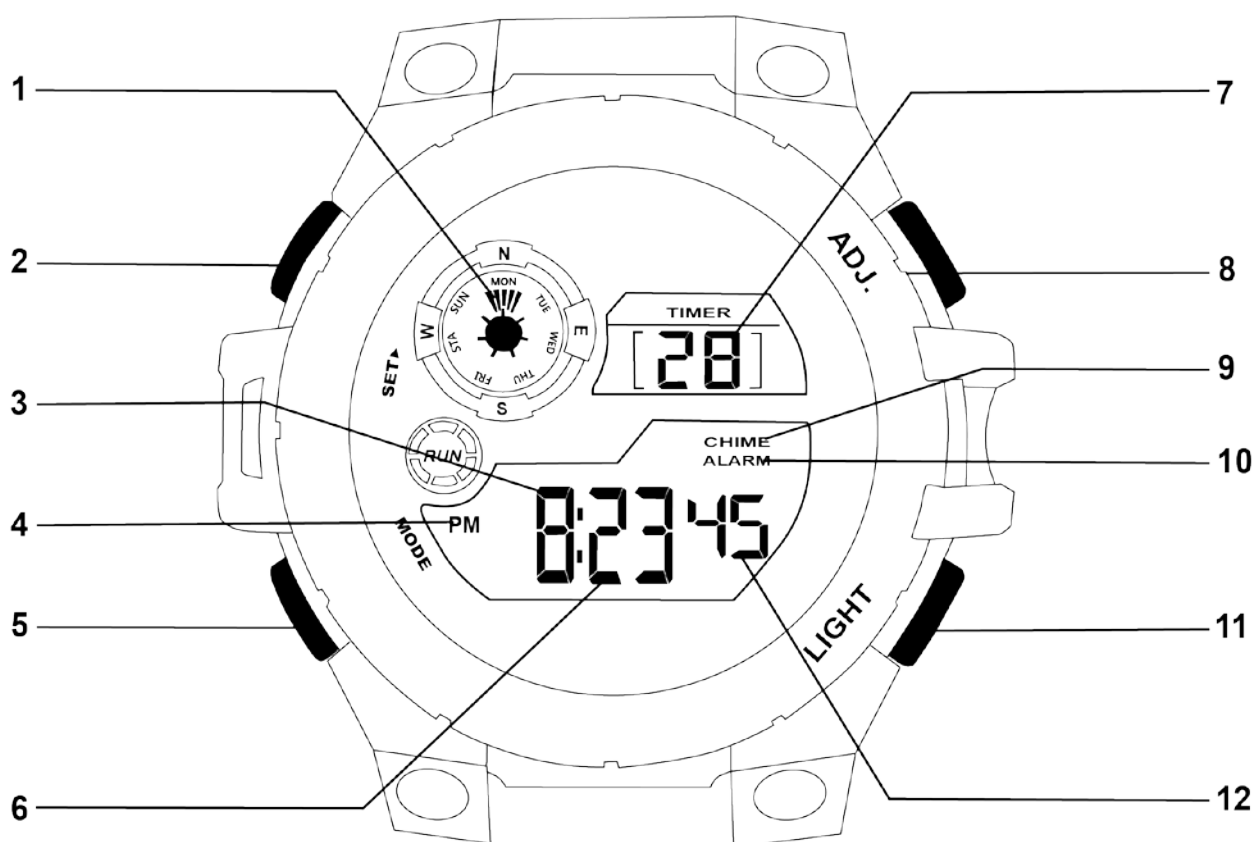

- |               |                  |
|---------------|------------------|
| 1. 曜日         | 7. 日付            |
| 2. 設定ボタン      | 8. ADJ ボタン       |
| 3. 時          | 9. 毎時チャイムインジケータ  |
| 4. PM インジケーター | 10. 目覚まし時計インジケータ |
| 5. モードボタン     | 11. ライトボタン       |
| 6. 分          | 12. 秒            |

## II. 現地時間の設定

2.1 現地時間表示モードで、秒の数字が点滅するまで **SET** ボタンを押し続け、次に **ADJ** ボタンを押して秒の数字を消去するか、次のステップにスキップします。



2.2 **MODE** ボタンを1回押すと、時桁が点滅し始めます。次に **ADJ** ボタンを押して時を設定します。

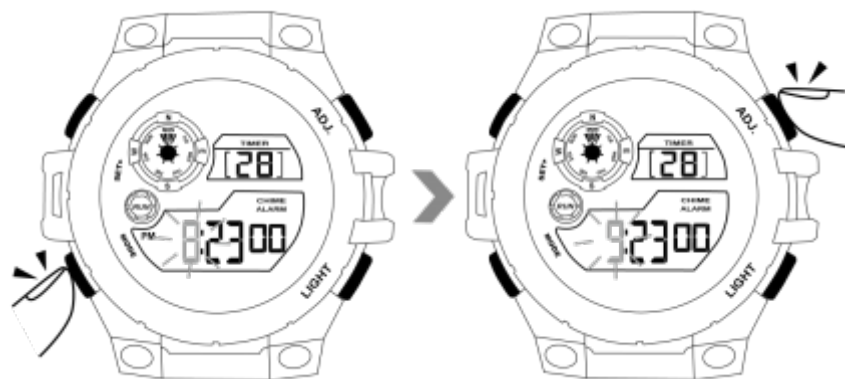

2.3 もう一度 **MODE** ボタンを押すと、分の桁が点滅し始め、**ADJ** ボタンを押して分を設定します。



2.4 もう一度 MODE ボタンを押すと、月の桁が点滅し始めます。そして ADJ ボタンを押して月を設定します。

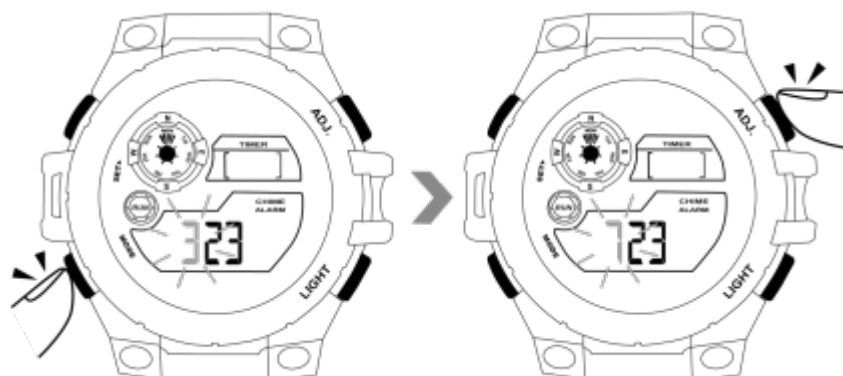

2.5 もう一度 MODE ボタンを押すと、日付の桁が点滅し始め、ADJ ボタンを押して日付を設定します。

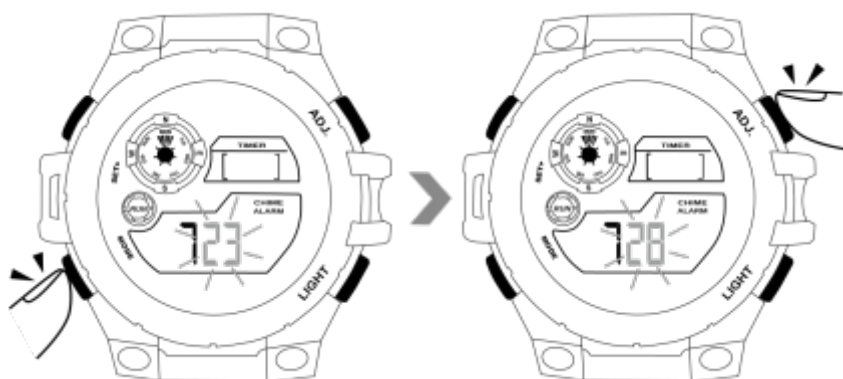

2.6 もう一度 MODE ボタンを押すと、曜日表示が点滅し始めます。次に ADJ ボタンを押して曜日を設定します。

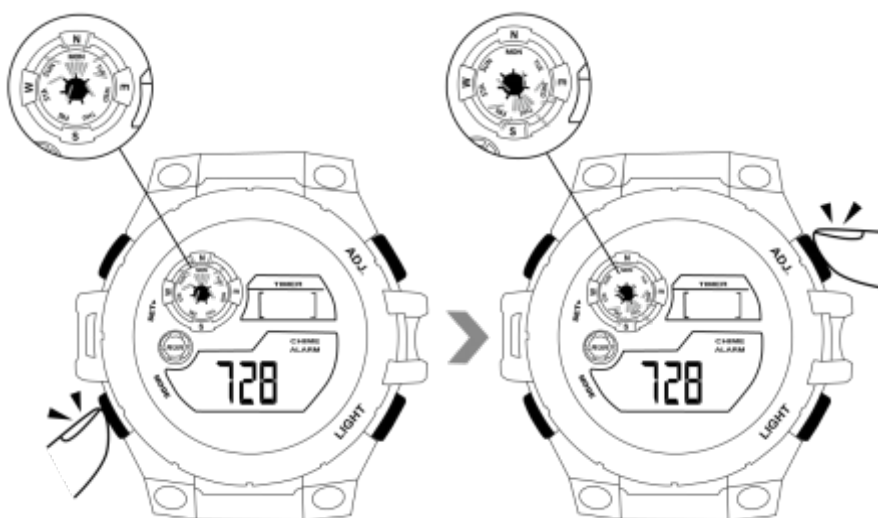

2.7 もう一度 MODE ボタンを押すと、時フォーマットの桁表示が点滅し始めます。次に ADJ ボタンを押して 12 または 24 時間フォーマットを選択します。

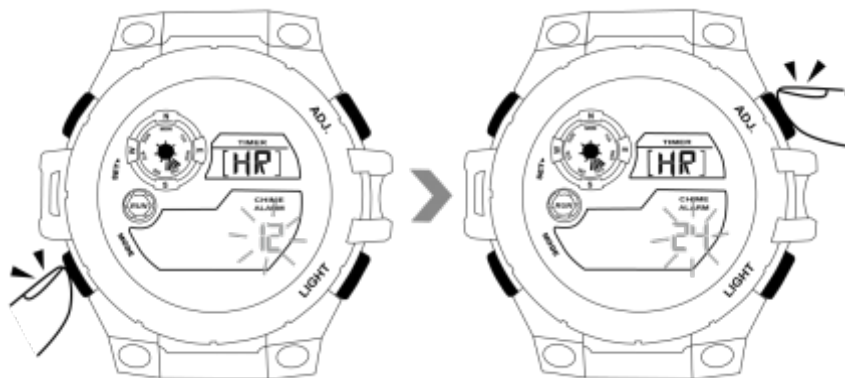

2.8 SET ボタンを 1 回押すとすべての設定が保存され、時計は現地時間表示モードに戻ります。

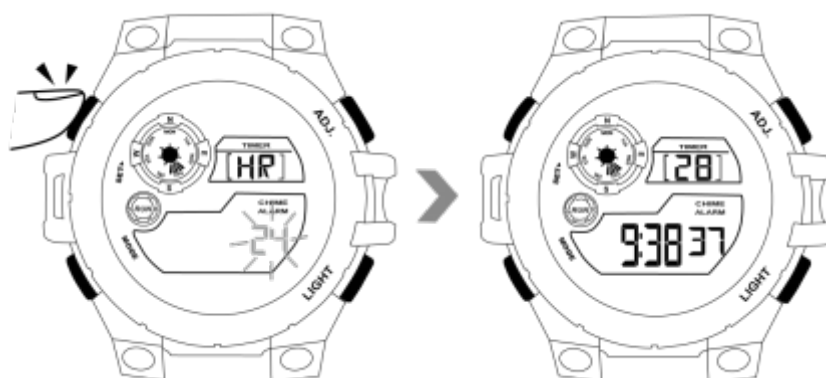

### III. ストップウォッチモード

3.1 現地時刻表示モードで、MODE ボタンを 1 回押してストップウォッチモードに入ります。

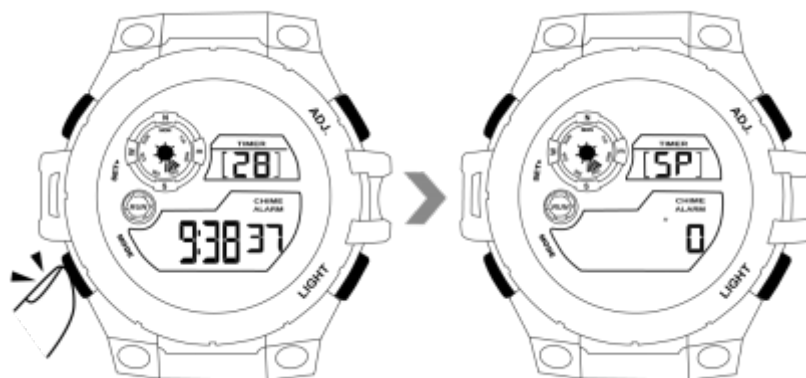

3.2 ADJ ボタンを押すと計時が始まります。



3.3 もう一度 ADJ ボタンを押すと計時が止まります。



3.4 クリアするには SET ボタンを押してください。

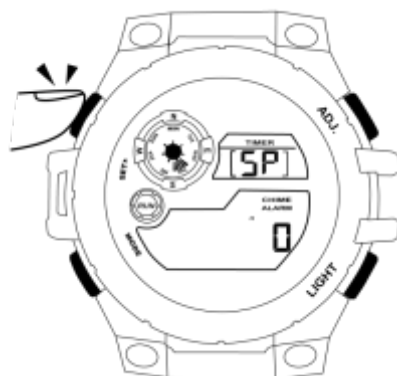

3.5 MODE ボタンを1回押してストップウォッチモードを終了します。

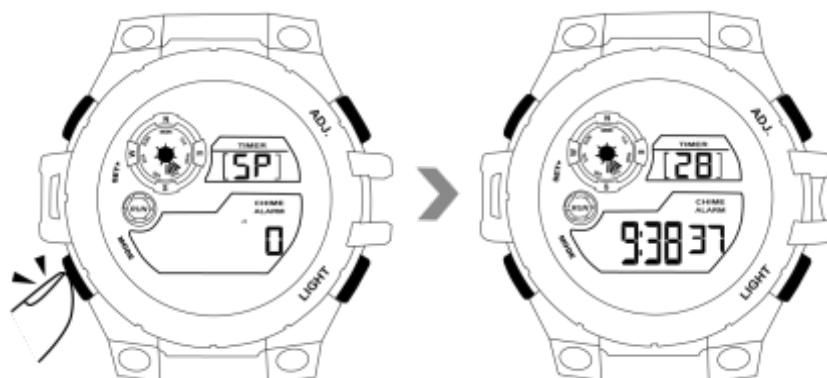

<注意>:

- 1.ストップウォッチのタイミング範囲は 0'00 "00～23: 59'59"です。
- 2.計時を停止しない場合は、計時が24時間を超えても計時を続け、計時を 0'0"00 から開始して計時モードを終了します。

## IV. 目覚まし時計

### 4.1 目覚まし時計を設定する

4.1.1 現地時刻表示モードで MODE ボタンを2回押すと、目覚まし設定モードになります。

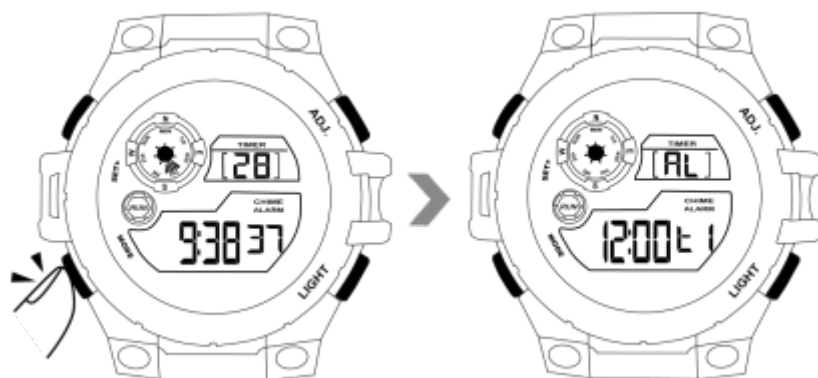

4.1.2 時間の桁が点滅するまで SET ボタンを押し続け、次に ADJ ボタンを押して時間を設定します。

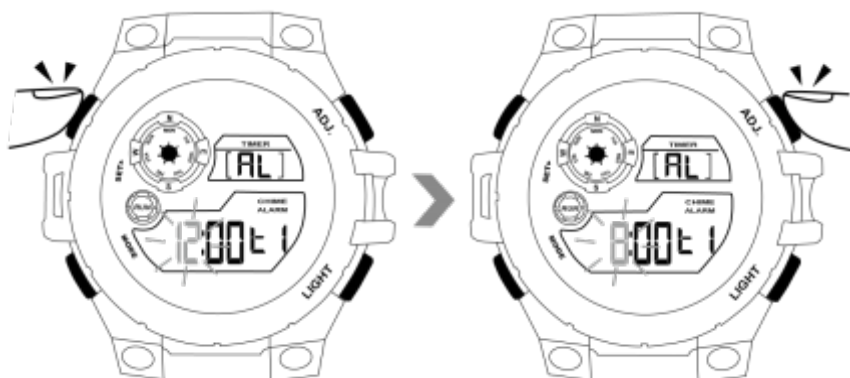

4.1.3 MODE ボタンを 1 回押すと、分の桁が点滅し始め、次に ADJ ボタンを押して分を設定します。

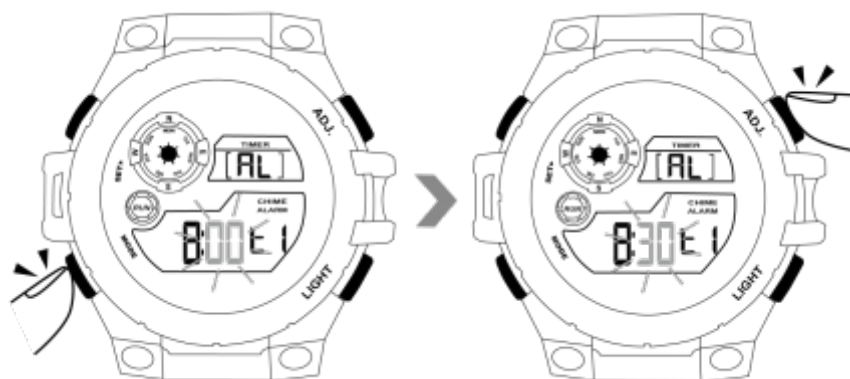

4.1.4 もう一度 MODE ボタンを押すと、タイムゾーンの数字表示が点滅し始めます。次に ADJ ボタンを押してタイムゾーンを選択します。注: L1 はローカルタイムゾーンの目覚まし時計、L2 は他のタイムゾーンの目覚まし時計です。

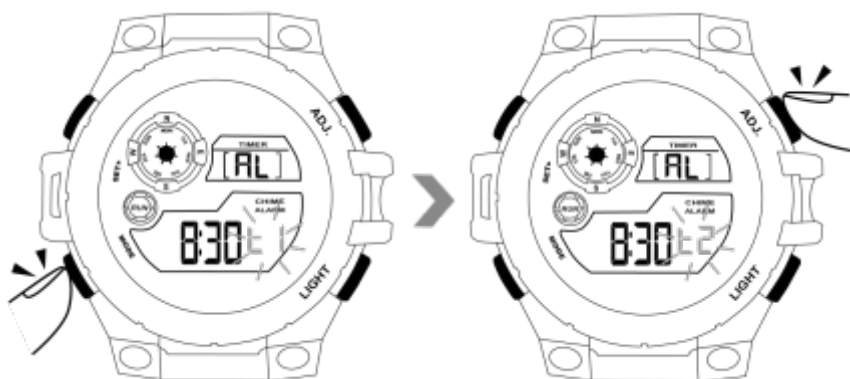



4.1.5 設定を保存するには、SET ボタンを 1 回押します。

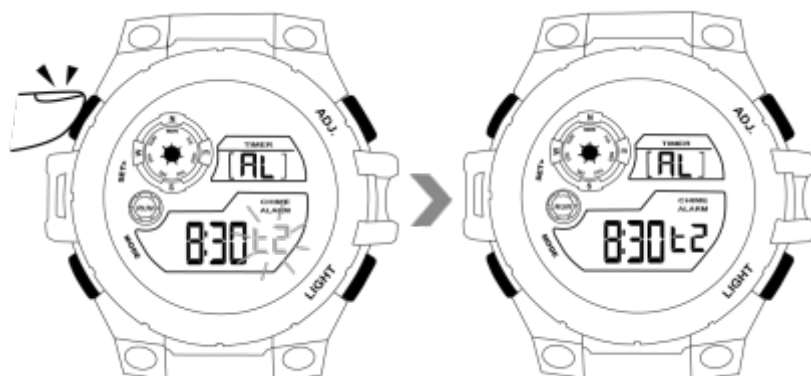

4.1.6 アラーム設定モードを終了するには、MODE ボタンを 1 回押します。

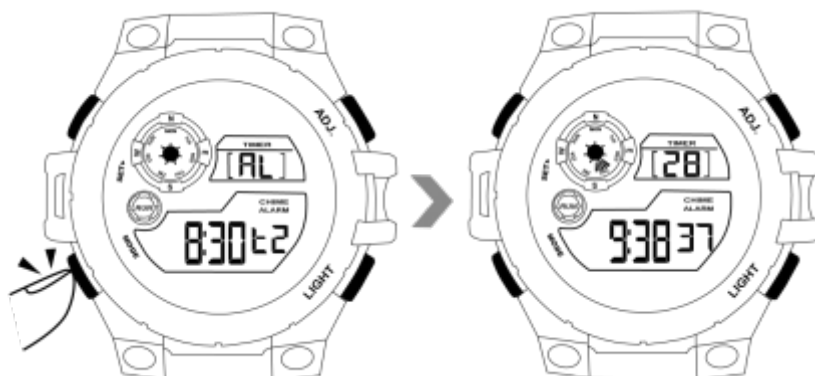

## 4.2 目覚まし時計のオン/オフ

目覚まし時計設定モードで、ADJ ボタンを押して、目覚まし時計をオンまたはオフにします。

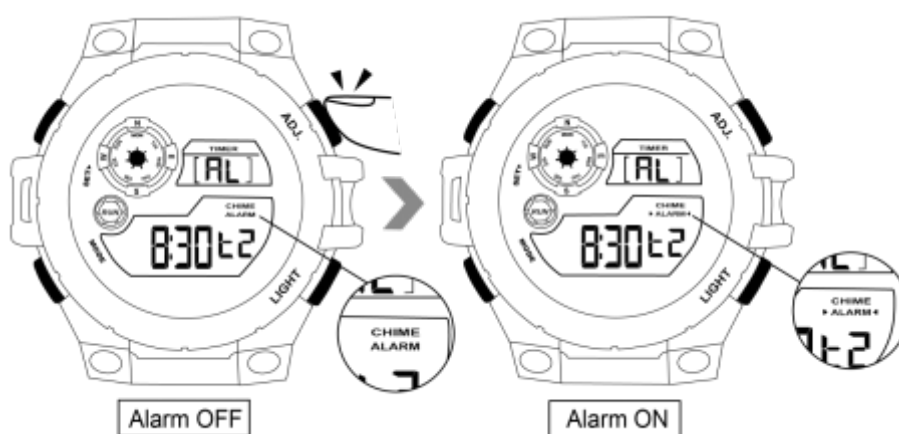

<注意>:

1.目覚まし時計の音は20秒間続きます。

あなたは目覚まし時計の音を停止するために時計の任意のボタンを押すことができます。

3.目覚まし時計は、毎日設定されています。

## V. 毎時チャイム機能のオン/オフ

5.1 目覚まし時計設定モードで ADJ ボタンを押すと、毎時チャイム機能のオン/オフが切り替わります。

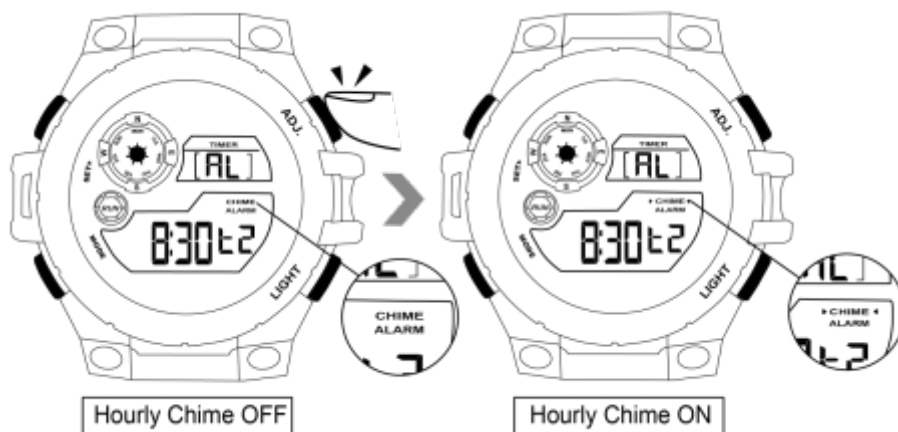

## VI. タイマーカウントダウン

6.1 現地時刻表示モードで、MODE ボタンを3回押して、タイマーカウントダウンモードに入ります。

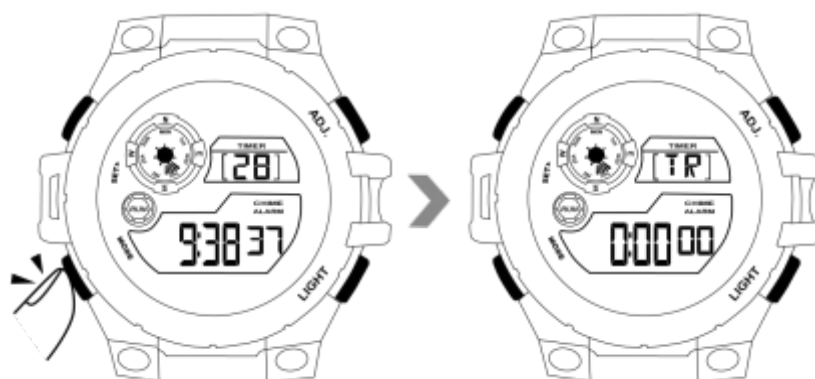

6.2 時間の桁が点滅するまで SET ボタンを押し続け、次に ADJ ボタンを押して時間を設定します。

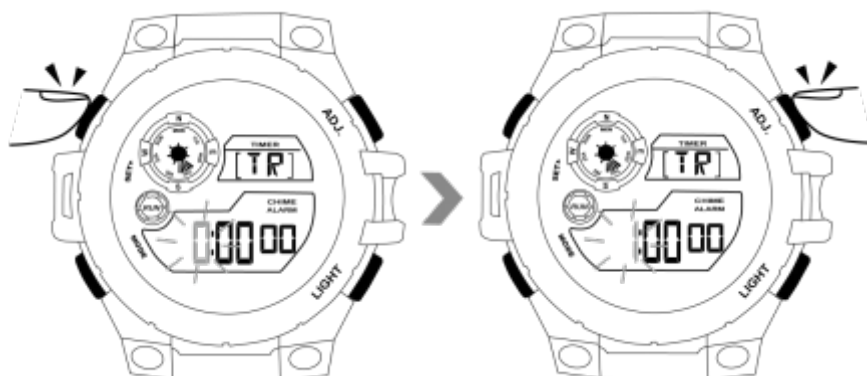

6.3 MODE ボタンを 1 回押すと、分の桁が点滅し始め、次に ADJ ボタンを押して分を設定します。

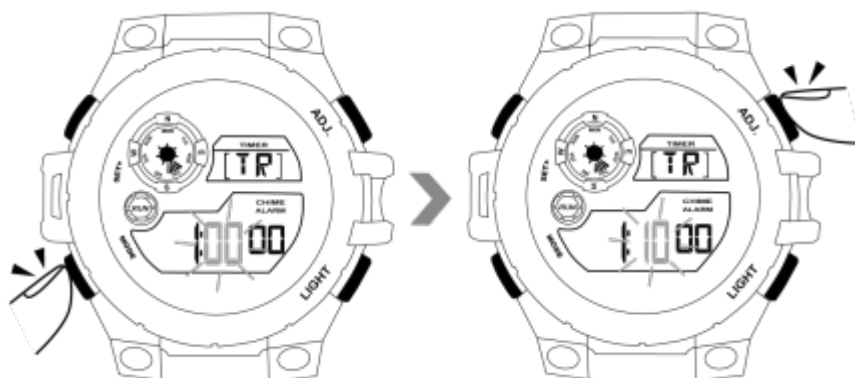

6.4 もう一度 MODE ボタンを押すと、秒の桁が点滅し始め、次に ADJ ボタンを押して秒を設定します。

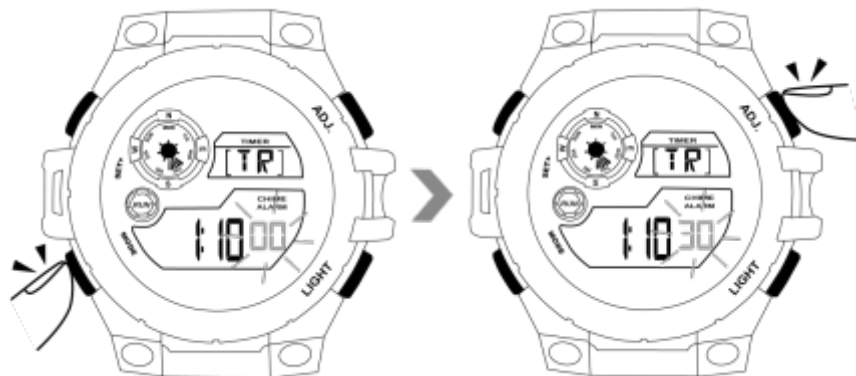

6.5 設定を保存するには、SET ボタンを 1 回押します。

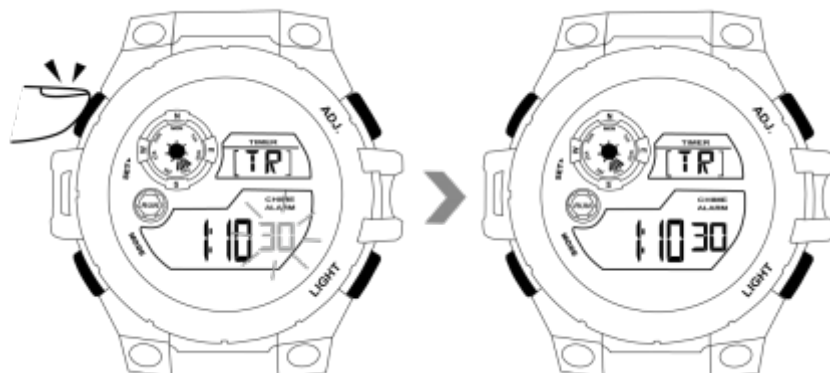

6.6 カウントダウンを開始するには、ADJ ボタンを押します。



6.7 カウントダウンを止めるには、もう一度 ADJ ボタンを押します。



6.8 MODE ボタンを1回押すとタイマーのカウントダウンを終了します。

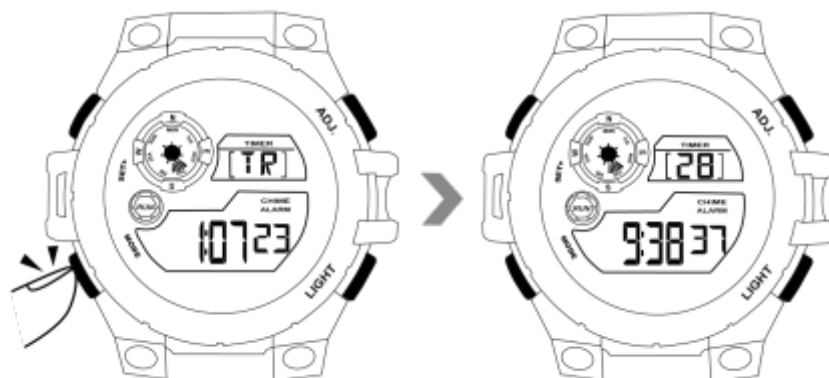

<注意>: カウントダウンが終了すると、時計が10秒間鳴り続けてスタートに戻ります。

## VII. バックライト

LIGHT ボタンを押してエレクトロルミネセントバックライトを点灯させます。バックライトは約3秒で自動的に消えます。

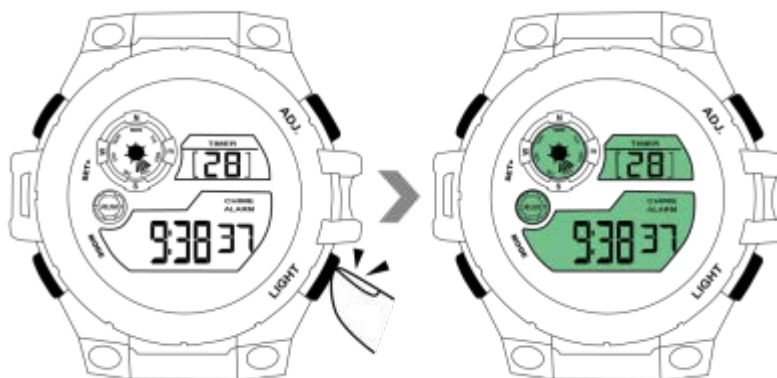

## VIII. 他のタイムゾーンの時間設定

8.1 現地時間表示モードで、MODE ボタンを4回押して、他のタイムゾーン表示モードに入ります。

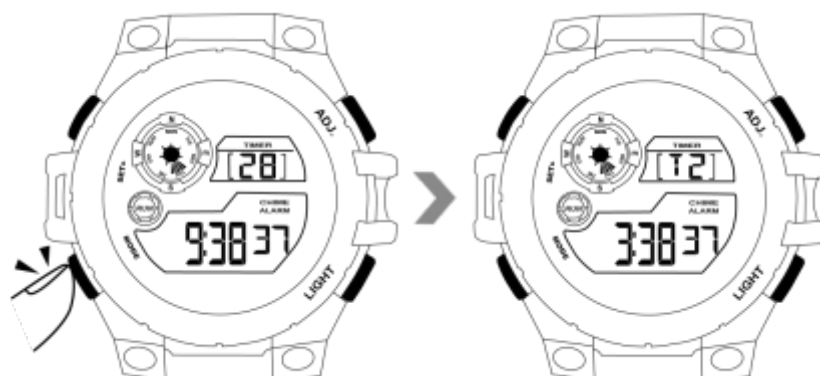

8.2 時間の桁が点滅するまで SET ボタンを押し続け、次に ADJ ボタンを押して時間を設定します。

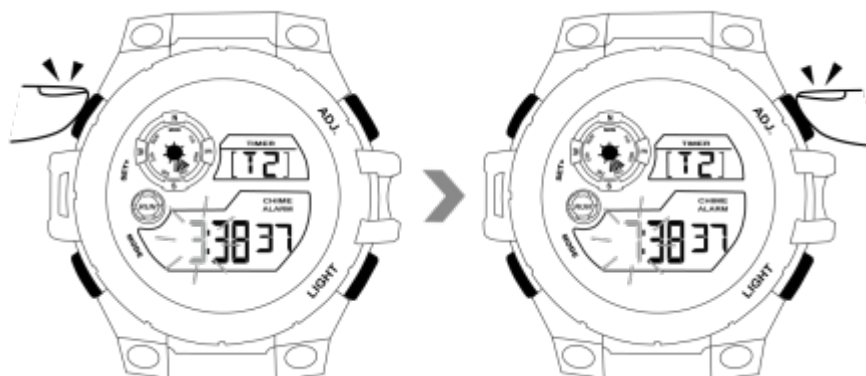

8.3 MODE ボタンを 1 回押すと、分の桁が点滅し始め、次に ADJ ボタンを押して分を設定します。

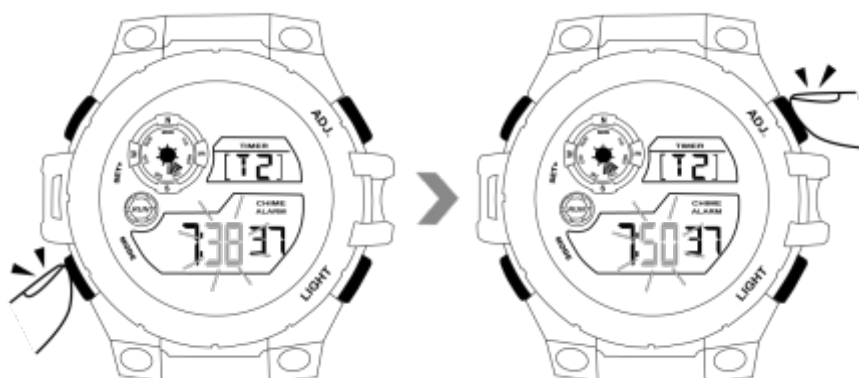

8.4 SET ボタンを押すと設定が保存されます。

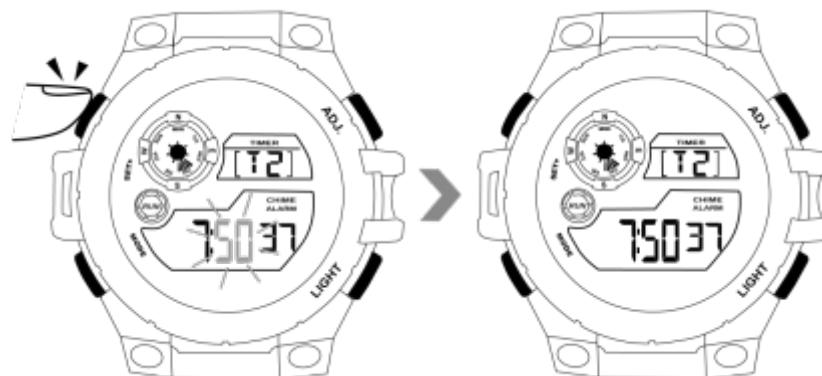

8.5 もう1つのタイムゾーン表示モードを終了するには、MODE ボタンを1回押します。

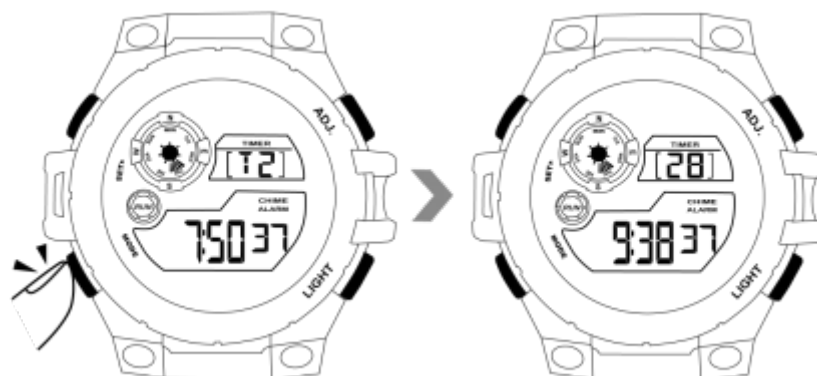

## IX. 月日チェック

現地時間表示モードで、ADJ ボタンを押して月日を確認します。



## X. 他のタイムゾーンの現在時刻を確認する

現地時刻表示モードで、MODE ボタンを4回押して、他のタイムゾーンの現在時刻を確認します。

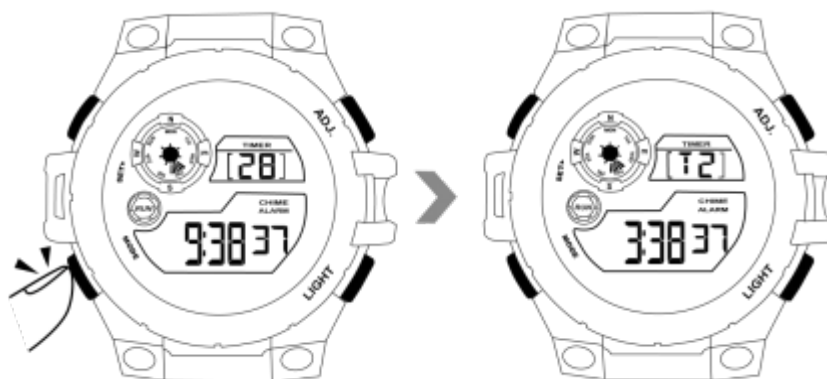

<終わり>